

## Hall Based Angle Position Encoder Sensor

### Features and Benefits

- Based on Hall Sensing Technology with 0°~360° Full Range Angle Sensing
- 3.3~5.0V Operation Power Supply, build in EEPROM (Programming at VDD>4.5V)
- Independent Output Interface: I<sup>2</sup>C, SSI, ABZ, UVW, Analog/PWM and Push-Button Function on Z-Axis
- Maximum Rotation Speed 55,000 RPM
- Output Propagation Delay <5 us
- Incremental ABZ Resolution 1~1024 Pulses per Revolution (PPR) User Programmable
- UVW Output Resolution 1~16 Pole-Pairs per Revolution User Programmable
- RoHS Compliant 2011/65/EU
- SOP-8 and QFN3x3-16L Package

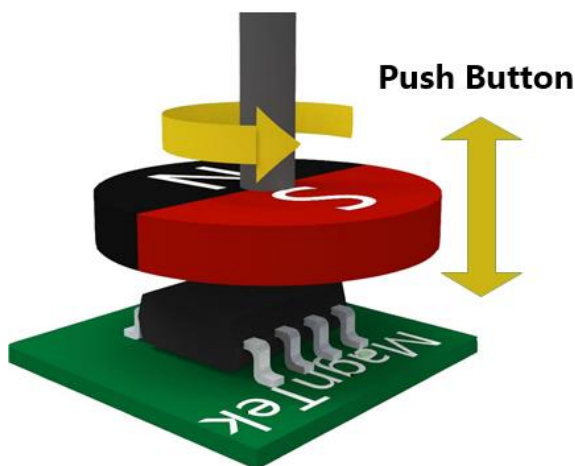

### Applications

- Absolute Linear Position Sensor
- Robotics Control
- Contactless Knob
- Contactless Potentiometer

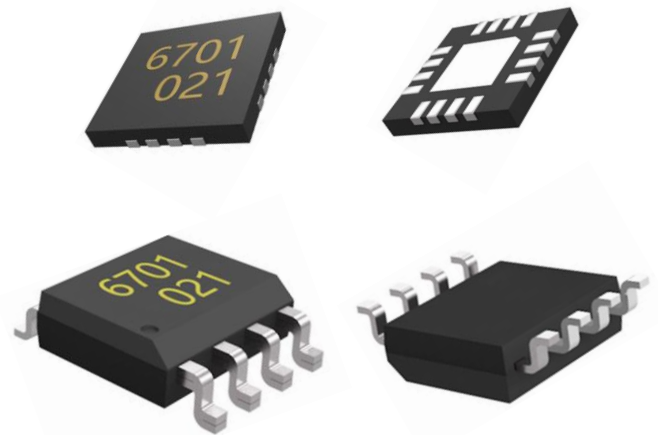

### General Description

The MagnTek rotary position sensor MT6701 is an IC based on Hall sensing technology. The chip senses the Z-Axis component of the rotating magnet in the X-Y plane and delivers two sinusoidal output signals to the DSP which indicating the angle ( $\alpha$ ) between the sensor and the magnetic field direction.

The incremental ABZ output mode is available in this sensor series, making the chip suitable to replace various optical encoders. The maximum resolution is 1024 pulses/4096 steps per revolution in binary mode.

A standard I<sup>2</sup>C or SSI interface allows a host microcontroller to read the 14-bit absolute angle position data from MT6701. The absolute angle position is also provided as PWM output or linear analog signal proportional to VDD from a 12-bit DAC.

Additionally, the PUSH output indicates the fast air-gap changes between the MT6701 and magnet which can be used to implement a contactless pushbutton function in which the knob can be pressed to move the magnet toward the MT6701.

### Table of Contents

<b>Features and Benefits</b> .....	1
<b>Applications</b> .....	1
<b>General Description</b> .....	1
<b>1 Pin Configuration</b> .....	3
1.1 SOP-8 Package.....	3
1.2 QFN-16 Package.....	4
<b>2 Part Number List</b> .....	5
<b>3 Function Diagram</b> .....	6
<b>4 Absolute Maximum Ratings</b> .....	6
<b>5 Electrical Characteristics</b> .....	7
<b>6 Magnetic Input Specifications</b> .....	9
<b>7 Output Mode</b> .....	10
7.1 I/O Pin Configuration.....	10
7.2 Reference Circuit for ABZ/UVW/PWM/Analog Output.....	11
7.3 Quadrature A,B and Zero-Position Output Signal (ABZ Mode).....	12
7.4 UVW Output Mode.....	17
7.5 Analog Output Mode.....	18
7.6 Pulse Width Modulation (PWM) Output Mode.....	19
7.7 I <sup>2</sup> C Interface.....	20
7.7.1 I <sup>2</sup> C Timing Diagram.....	21
7.7.2 I <sup>2</sup> C Read Angle Registers.....	22
7.7.3 I <sup>2</sup> C Write Registers.....	23
7.8 SSI Interface.....	24
7.7.1 SSI Timing Diagram.....	25
7.7.2 SSI Read Angle.....	26
7.9 Pushbutton Output.....	27
<b>8 Register Map &amp; EEPROM Programming</b> .....	28
8.1 Register Map.....	28
8.2 EEPROM Programming.....	32
<b>9 Mechanical Angle Direction</b> .....	33
<b>10 Package Information</b> .....	34
10.1 SOP-8 Package.....	34
10.2 QFN-16 Package.....	35
<b>11 Copy Rights and Disclaimer</b> .....	36
<b>12 Revision History</b> .....	37

### 1. Pin Configuration

#### 1.1 SOP-8 Package

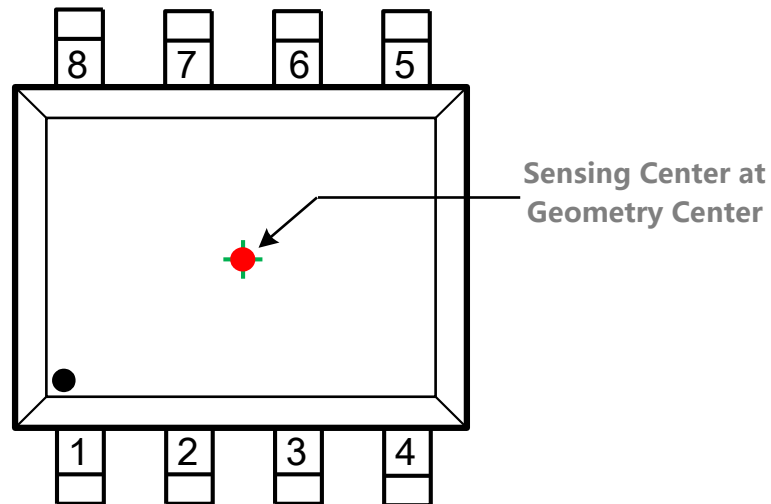

Figure-1: Pin Configuration for SOP-8 Package

#### Pin List

Name	#	Type	Description
VDD	1	Power Supply	3.3~5.0V Supply
MODE	2	Digital Input with Build in 200KΩ Pull-up Resistor	ABZ or I <sup>2</sup> C/SSI Selection
OUT	3	Analog/Digital Output	Analog or PWM Output
GND	4	Power Supply	Ground
PUSH	5	Digital Output	Push Button Function Output
A	6	Digital Input/output	Incremental Signal A/U or I <sup>2</sup> C Data 'SDA' , or SSI Data 'DO'
B	7	Digital Input/output	Incremental Signal B/V or I <sup>2</sup> C Clock 'SCL' , or SSI Clock 'CLK'
Z	8	Digital Input/output with Build in 200KΩ Pull-up Resistor	Incremental Signal Z/W or SSI 'CSN'

\*SOP-8 Reflow Sensitivity Classification: MSL-3

## Hall Based Angle Position Encoder Sensor

### 1.2 QFN-16 Package

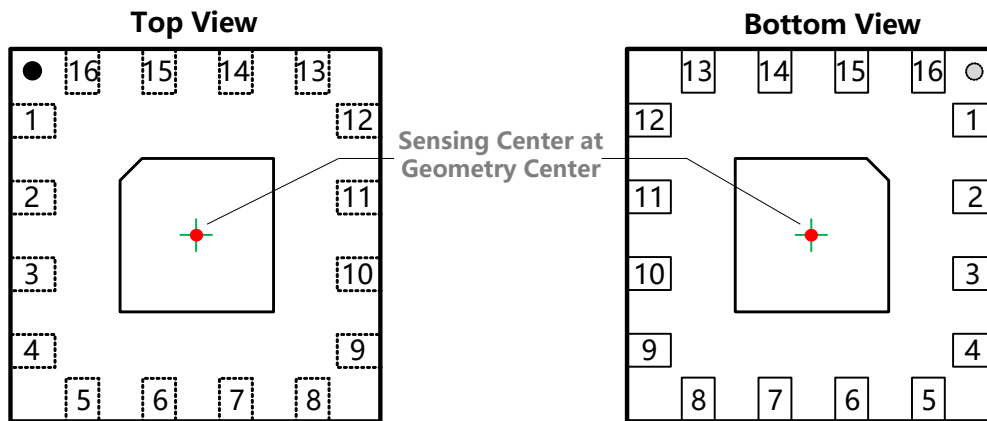

**Figure-2: Pin Configuration for QFN-16 Package**

#### Pin List

Name	#	Type	Description
NC	1	-	Not Connected
NC	2	-	Not Connected
NC	3	-	Not Connected
NC	4	-	Not Connected
PUSH	5	Digital Output	Push Button Function Output
A	6	Digital Input/output	Incremental Signal A, or I <sup>2</sup> C data 'SDA' , or SSI data 'DO'
B	7	Digital Input/output	Incremental Signal B, or I <sup>2</sup> C clock 'SCL' , or SSI Clock 'CLK'
Z	8	Digital Input/output with Build in 200KΩ Pull-up Resistor	Incremental Signal Z, or SSI 'CSN'
W	9	Digital Output	Incremental Signal W or -Z
NC	10	-	Not Connected
U	11	Digital Output	Incremental Signal U or -A
V	12	Digital Output	Incremental Signal V or -B
VDD	13	Power Supply	3.3~5.0V Supply
MODE	14	Digital Input with Build in 200KΩ Pull-up Resistor	ABZ or I <sup>2</sup> C/SSI Selection
OUT	15	Analog/Digital Output	Analog or PWM Output
GND	16	Power Supply	Ground

**\*QFN-16 Reflow Sensitivity Classification: MSL-1**

## Hall Based Angle Position Encoder Sensor

### 2. Part Number List

MT6701CT is in an SOP-8 package (Reflow Sensitivity Classification: **MSL-3**), and both Tube Pack (**100pcs/Tube**) and Tape & Reel Pack (**3000pcs/Reel**) are provided. MT6701QT is in a QFN3x3-16L package (Reflow Sensitivity Classification: **MSL-1**), only Tape & Reel Pack (**1000pcs/Reel**) is provided.

#### Part Number List

Part Number	Description
MT6701CT-STD	SOP-8 Standard Part Number: I <sup>2</sup> C, SSI; AB=1 PPR, Z=1 LSB; Analog Output 0~360°; CCW Rotate Angle Increase;
MT6701QT-STD	QFN3x3 Standard Part Number: I <sup>2</sup> C, SSI; AB=1 PPR, Z=1 LSB; UVW=1 Pole-Pair Analog Output 0~360°; CCW Rotate Angle Increase;
MT6701CT-AKD	AB=1,000 PPR, Z=4 LSB; Analog Output 0~360°; CCW Rotate Angle Increase;
MT6701CT-AKE	AB=1,000 PPR, Z=1 LSB; Analog Output 0~360°; CCW Rotate Angle Increase;
MT6701CT-ACD	AB=1,024 PPR, Z=4 LSB; Analog Output 0~360°; ; CCW Rotate Angle Increase;
MT6701CT-A200	AB=200 PPR, Z=1 LSB; Analog Output 0~360°; CCW Rotate Angle Increase;
MT6701CT-A360	AB=360 PPR, Z=1 LSB; Analog Output 0~360°; CCW Rotate Angle Increase;
MT6701CT-A400	AB=400 PPR, Z=1 LSB; Analog Output 0~360°; CCW Rotate Angle Increase;
MT6701CT-A600	AB=600 PPR, Z=4 LSB; Analog Output 0~360°; CCW Rotate Angle Increase;
MT6701CT-A800	AB=800 PPR, Z=4 LSB; Analog Output 0~360°; CCW Rotate Angle Increase;
MT6701CT-STV	I <sup>2</sup> C, SSI; AB=1 PPR, Z=1 LSB; Analog Output 0~360°; <b>CW</b> Rotate Angle Increase;
MT6701QT-ACD	AB=1,024 PPR, Z=1 LSB; UVW=-A-B-Z; Analog Output 0~360°; CCW Rotate Angle Increase;

### 3. Functional Diagram

The MT6701 is manufactured in a CMOS standard process and uses advanced magnet sensing technology to sense the magnetic field distribution across the surface of the chip. The integrated magnetic sensing element array is placed around the center of the device and delivers a voltage representation of the magnetic field at the surface of the IC.

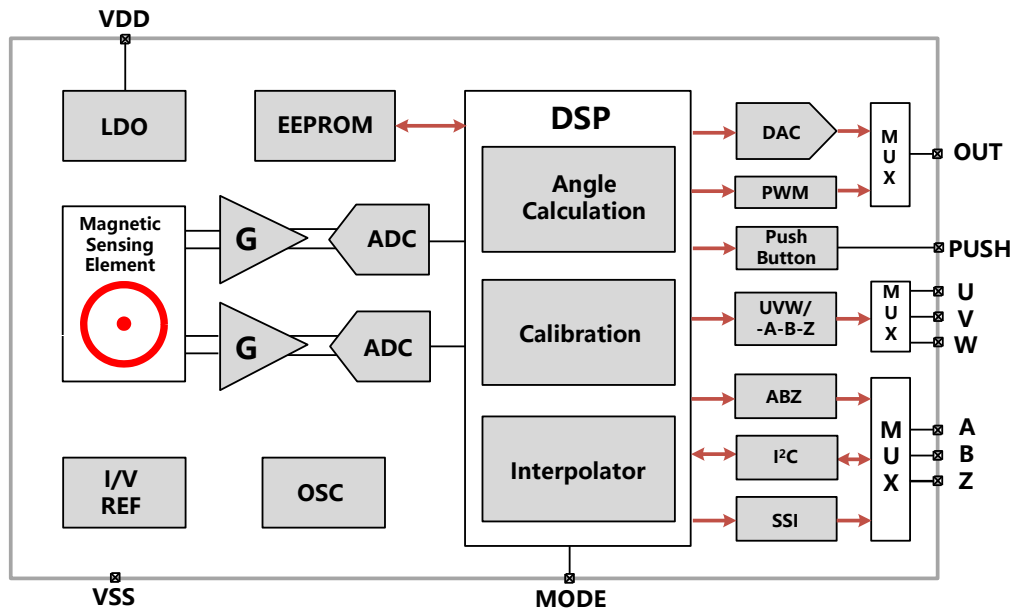

Figure-3: Block Diagram

Figure-3 shows a simplified block diagram of the chip, consisting of the magnetic sensing element modeled by two interleaved Wheatstone bridges to generate cosine and sine signals, gain stages, analog-to-digital converters (ADC) for signal conditioning, and a digital signal processing (DSP) unit for encoding. Other supporting blocks such as LDO, etc. are also included.

### 4. Absolute Maximum Ratings (Non-Operating)

Stresses beyond those listed under “Absolute Maximum Ratings” may cause permanent damage to the device. These are stress ratings only. Functional operation of the device at these or any other conditions beyond those indicated under “Operating Conditions” is not implied. Exposure to absolute maximum rating conditions for extended periods may affect device reliability.

Name	Min.	Max.	Unit
DC Voltage at Pin VDD	-0.5	7	V
Storage Temperature	-55	150	°C
Operating Temperature	-40	125	°C
Electrostatic Discharge (HBM)	-	±6.0	kV
Electrostatic Discharge (CDM)	-	±1.5	kV

## Hall Based Angle Position Encoder Sensor

### 5. Electrical Characteristics

Operation conditions: Ta=-40 to 125°C, VDD=3.0~5.5V unless otherwise noted.

Symbol	Parameter	Conditions/Notes	Min.	Typ.	Max.	Unit
VDD	Supply Voltage	-	3.0	3.3~5.0	5.5	V
I <sub>dd</sub>	Supply Current	-		10.0	14.0	mA
LSB	Resolution (ABZ Mode)	N Steps per Cycle		360°/N	-	°
INL	Integral Non-Linearity	<b>Note[1]</b>	-	±1.0	±1.5	°
DNL	Differential Non-Linearity (ABZ Mode), <b>Figure-4</b>		-	±0.02	-	°
TN	Transition Noise (ABZ Mode)	25°C	-	0.01		°rms
Hyst	Hysteresis (ABZ Mode)		-	0.088	-	°
T <sub>PwrUp</sub>	Power-Up Time	VDD Ramp<10us	-	-	32	ms
T <sub>Delay</sub>	Propagation Delay	Constant Speed	-	5	-	us

#### Analog Output Specification

R <sub>OUT</sub>	Analog Output Resistance	-	-	15	30	Ω
R <sub>L</sub>	Pull-Up or Pull-Down	-	10	-	-	KΩ
C <sub>L</sub>	Loading Capacitor	-	-	-	1	nF
V <sub>Sat_High</sub>	Saturation High Voltage	I <sub>load</sub> =1mA	VDD-0.5	-	-	V
V <sub>Sat_Low</sub>	Saturation Low Voltage	I <sub>load</sub> =1mA	-	-	0.5	V
DAC_LSB	DAC LSB	12-bit DAC	-	0.0244	-	%VDD
V <sub>Noise</sub>	Analog Output Noise	Ta=25°C, RMS Value excluding DAC Quantization Noise	-	-	0.5	mVrms
E <sub>rm</sub>	Ratiometric Error	<b>Note[2]</b>	-0.3	-	0.3	%

#### PWM Output Characteristics

FPWM	PWM Frequency	Programmable	-5% @27°C	994.4 /497.2	+5% @27°C	Hz
T <sub>Rise</sub>	Rising Time	C <sub>L</sub> =1nF	-	-	1	us
T <sub>Fall</sub>	Falling Time	C <sub>L</sub> =1nF	-	-	1	us

## Hall Based Angle Position Encoder Sensor

### Digital I/O Characteristics (Push-Pull Type in Normal Mode)

V <sub>IH</sub>	High Level Input Voltage	-	0.7*VDD	-	-	V
V <sub>IL</sub>	Low Level Input Voltage	-	-	-	0.3*VDD	V
V <sub>OH</sub>	GPIO Output High Level	Push-pull (I <sub>out</sub> =2mA)	VDD-0.5	-	-	V
V <sub>OL</sub>	GPIO Output Low Level	Push-pull (I <sub>out</sub> =2mA)	-	-	0.5	V
I <sub>LK</sub>	Input Leakage Current	-	-	-	±1	uA
T <sub>RISE</sub>	Digital Output Rise Time	Push-Pull, C <sub>Load</sub> =20pf			40	ns
T <sub>FALL</sub>	Digital Output Fall Time	Push-Pull, C <sub>Load</sub> =20pf			40	ns

**Note[1]:** The typical error value can be achieved at room temperature and with no off-axis misalignment error. The maximum error value can be achieved over operation temperature range, at maximum air gap and with worst-case off-axis misalignment error.

**Note[2]:** The analog output is by design ratiometric, i.e., it is proportional to the supply voltage VDD. The ratiometric error is calculated as follows.

$$E_{rm} = \left[ \frac{V_{out}(V_{DD})}{V_{DD}} - \frac{V_{out}(5V)}{5V} \right] \cdot 100\%$$

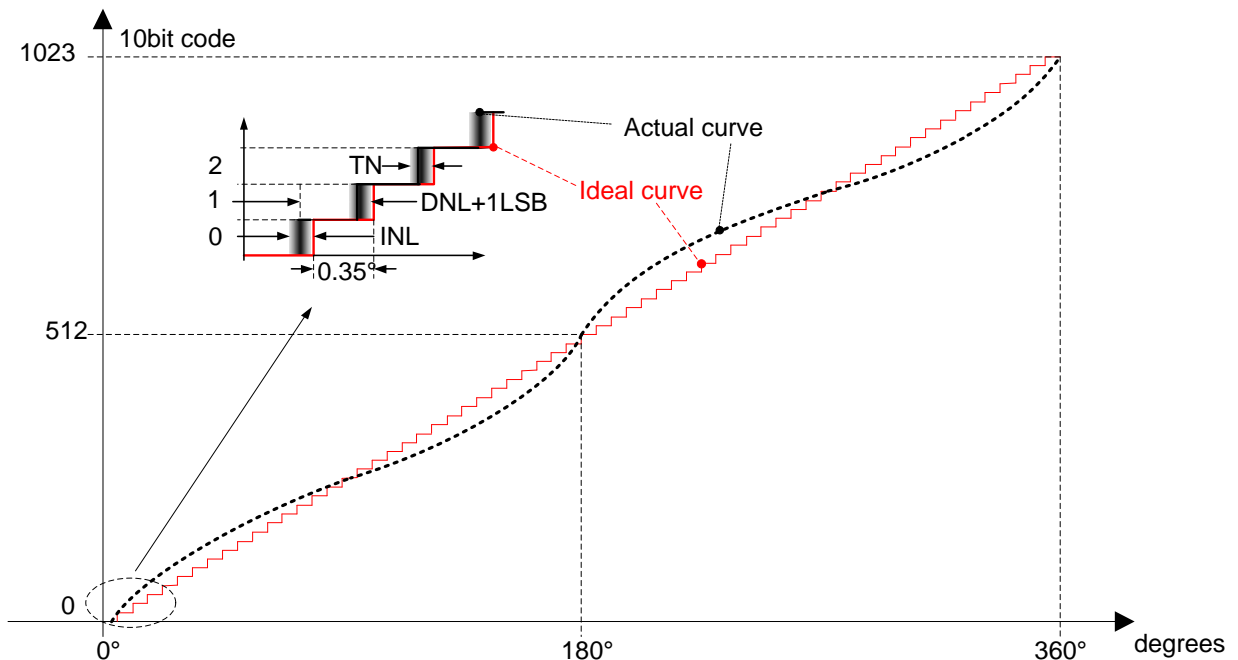

**Figure-4: Drawing Illustration INL, DNL and TN (for 10-bit case)**



### 6. Magnetic Input Specifications

Operation conditions:  $T_a = -40$  to  $125^\circ\text{C}$ ,  $V_{DD} = 3.0 \sim 5.5\text{V}$  unless otherwise noted, two-pole cylindrical diametrically magnetized source.

Symbol	Parameter	Conditions/Notes	Min.	Typ.	Max.	Unit
Dmag	Diameter of Magnet	Recommended Magnet: $\varnothing 6\text{mm}$ x 2.5mm for Cylindrical Magnets	-	6.0	-	mm
Tmag	Thickness of Magnet		-	2.5	-	mm
Bpk	Magnetic Input Field Amplitude Cross MT6701	Measure at the IC Surface	200	-	1,000	Gauss
AG	Air Gap	Magnetic to IC Surface Distance	0.5	1.0	2.0	mm
RS	Rotation Speed		-	-	55,000	RPM
DISP	Off Axis Misalignment	Misalignment Error Between Sensor Sensing Center and Magnet Axis (See <b>Figure-5</b> )	-	-	0.3	mm
TCmag1	Recommended Magnet Material and Temperature	NdFeB (Neodymium Iron Boron)	-	-0.12	-	%/ $^\circ\text{C}$
TCmag2	Drift Coefficient	SmCo (Samarium Cobalt)	-	-0.035	-	

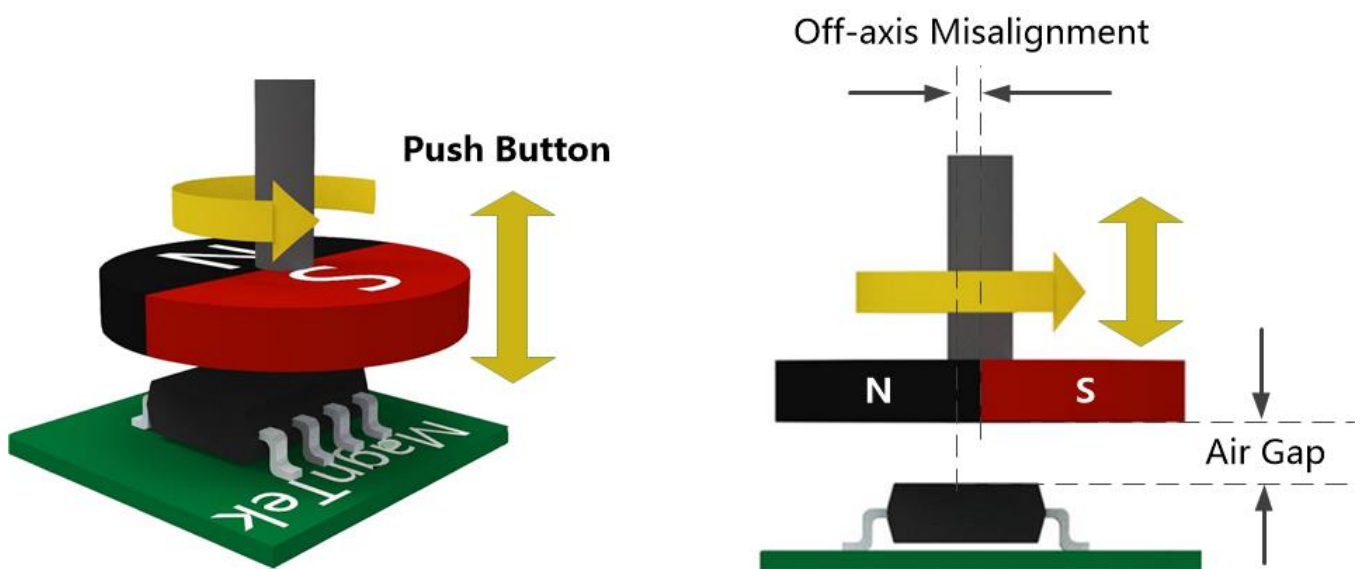

**Figure-5: Magnet Arrangement**

### 7. Output Mode

The MT6701 provides ABZ, UVW, Analog and PWM at output pins, also angle position data could be transferred by I<sup>2</sup>C or SSI interface. A PUSH output indicating pushbutton function is also provided.

#### 7.1 I/O Pin Configuration

For SOP-8 package, ABZ/UVW (Single-end), I<sup>2</sup>C and SSI are configured to Pin.6, Pin.7 and Pin.8. Analog and PWM output is configured to Pin.3.

##### *SOP-8 Package I/O Pin Configuration*

Pin#	I <sup>2</sup> C	SSI	ABZ	UVW	PWM	Analog	Push
3					PWM	Analog	
5							Push
6	SDA	DO	A	U			
7	SCL	CLK	B	V			
8		CSN	Z	W			

For QFN-16 package, ABZ (Single-end), I<sup>2</sup>C and SSI are configured to Pin.6, Pin.7 and Pin.8. UVW and –A-B-Z are configured to Pin.11, Pin.12 and Pin.9. Analog and PWM output is configured to Pin.15.

##### *QFN-16 Package I/O Pin Configuration*

Pin#	I <sup>2</sup> C	SSI	ABZ	ABZ+UVW	ABZ Differential	PWM	Analog	Push
5								Push
6	SDA	DO	A	A	A			
7	SCL	CLK	B	B	B			
8		CSN	Z	Z	Z			
9				W	-Z			
11				U	-A			
12				V	-B			
15						PWM	Analog	

### 7.2 Reference Circuit for ABZ/UVW/PWM/Analog/Push Output

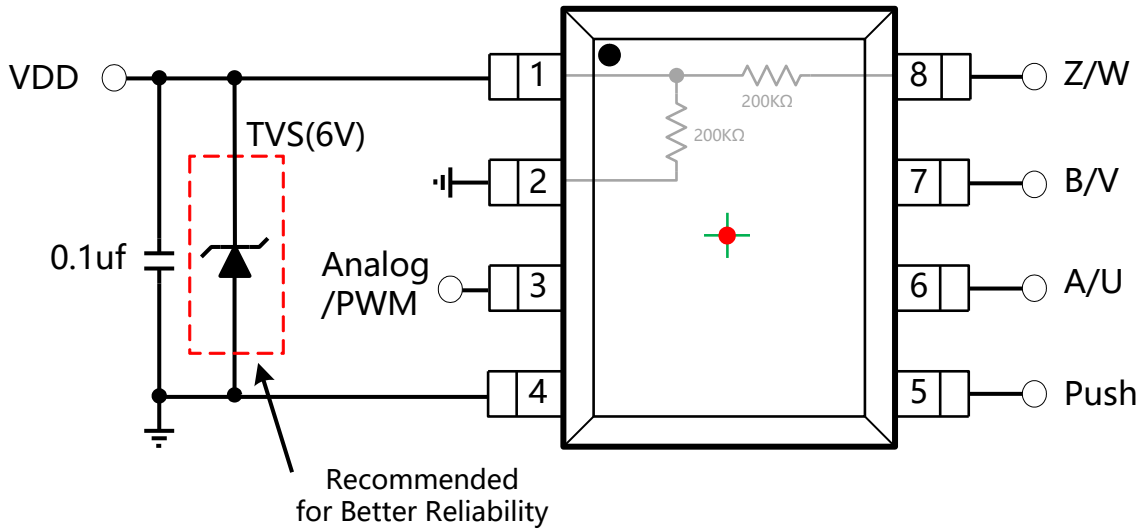

Figure-6: MT6701CT(SOP-8) Reference Circuit for ABZ/UVW/PWM/Analog/Push Output

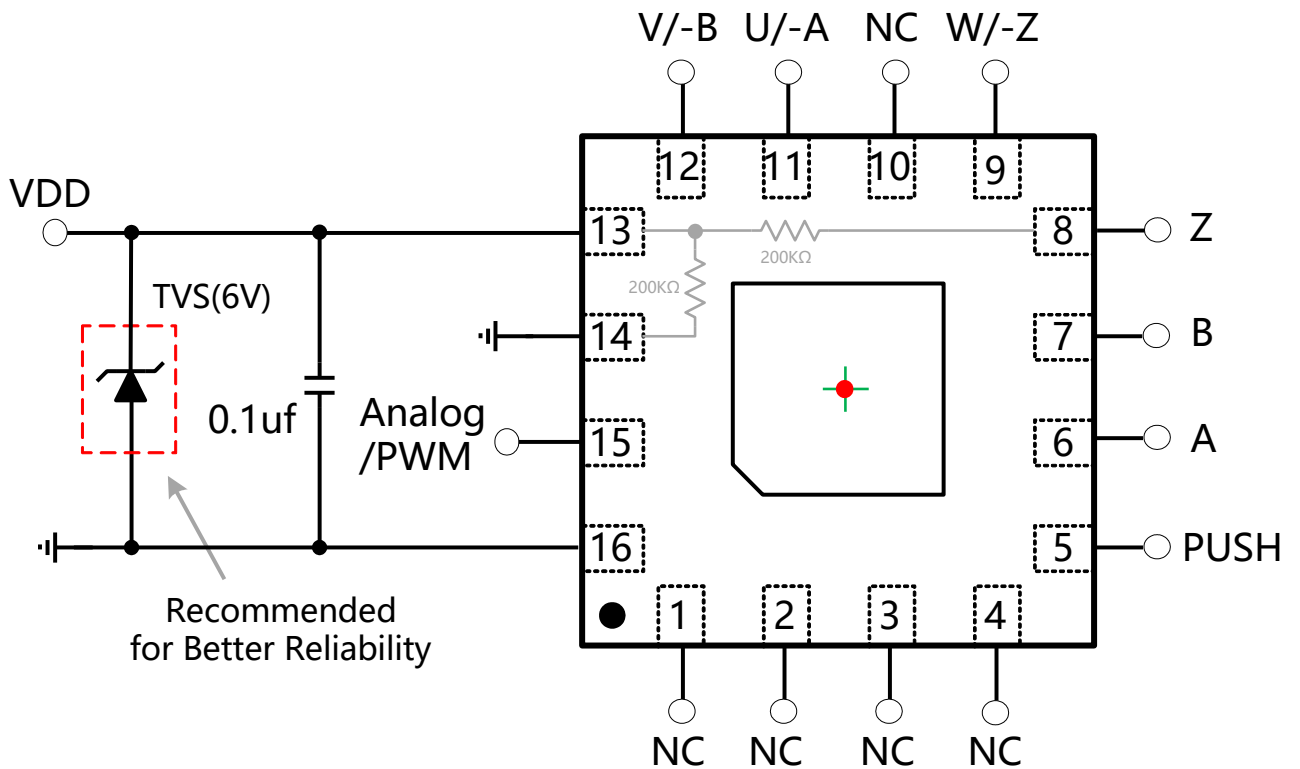

Figure-7: MT6701QT(QFN-16) Reference Circuit for ABZ/UVW/PWM/Analog/Push Output

## Hall Based Angle Position Encoder Sensor

### 7.3 Quadrature A, B and Index Output

As shown in Figure-8(1), when the magnet rotates counter-clock-wise (CCW), output B leads output A by 1/4 cycle, when the magnet rotates clock-wise (CW), output A leads output B by 1/4 cycle (or 1 LSB). Output Z indicates the zero position of the magnet.

After chip power-on, the ABZ output is blocked for 50ms to guarantee proper output.

#### Top View

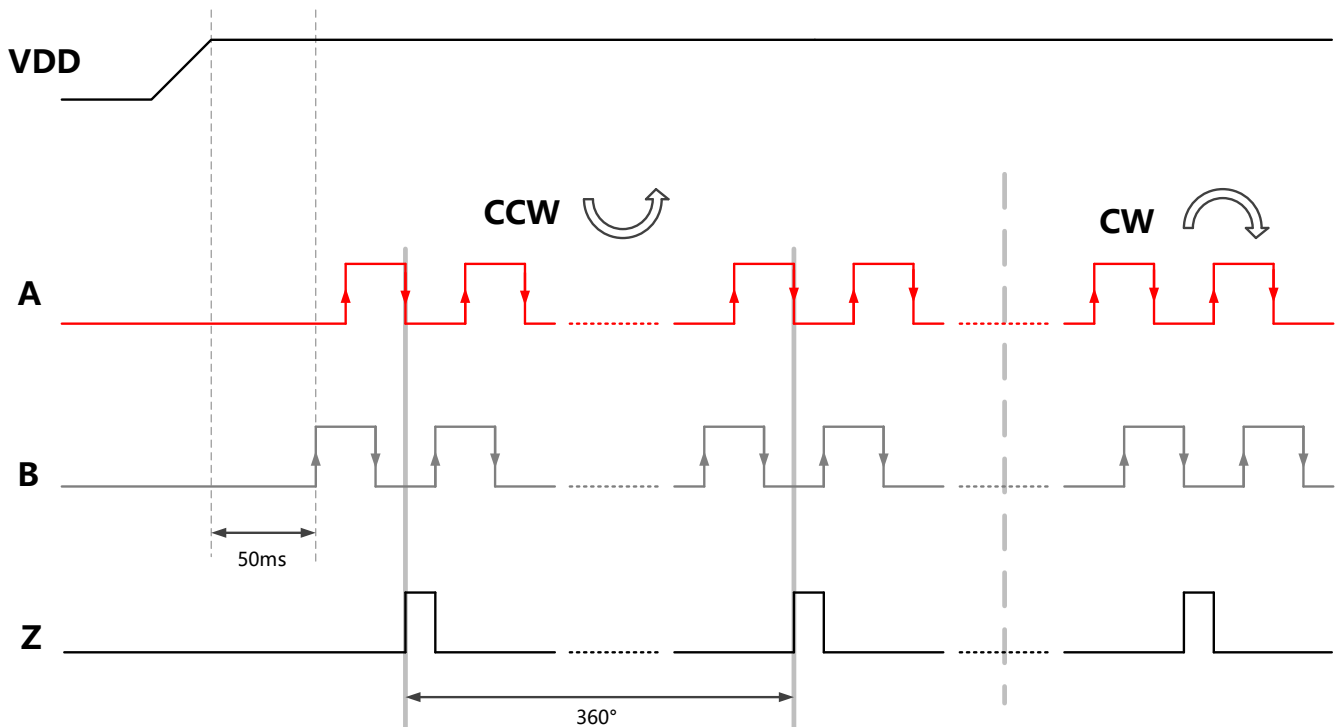
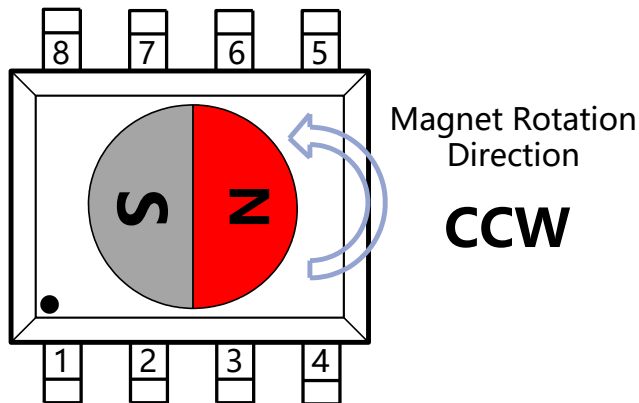
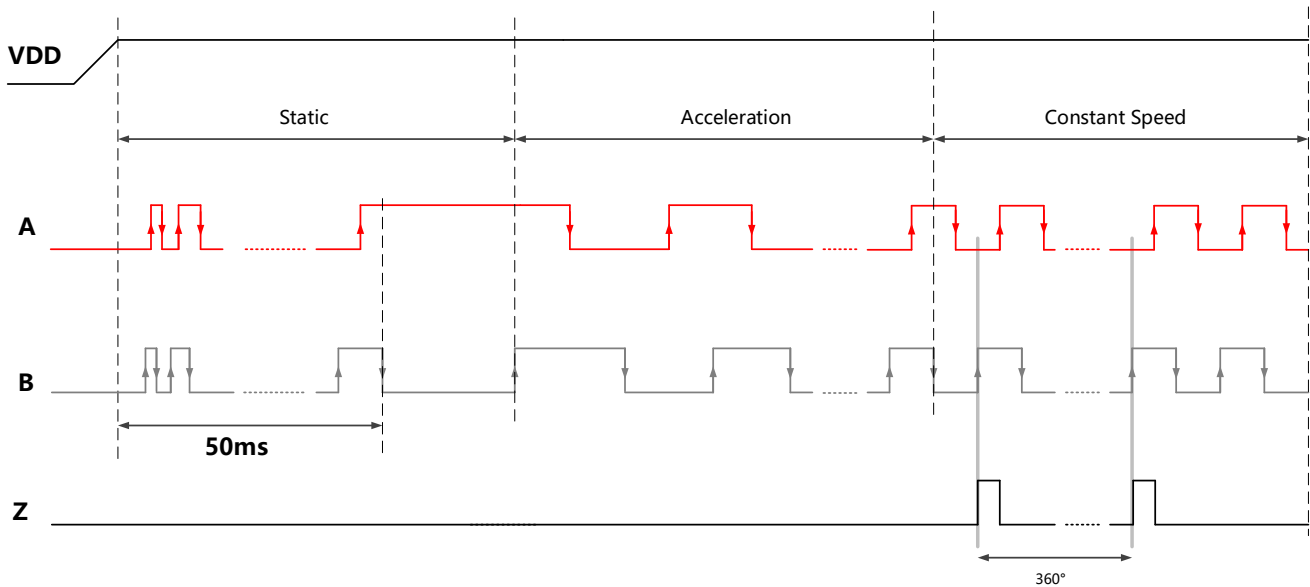

Figure-8(1): ABZ Output Power On without Absolute Position Indicate Pulses

## Hall Based Angle Position Encoder Sensor

After startup, there is an option of MT6701 to transmit a number of AB pulses which correspond to the actual absolute angle value as shown in Figure-8(2). Thus, the microcontroller gets the information about the absolute position.



**Figure-8(2): ABZ Output Power On with Absolute Position Indicate Pulses**

## Hall Based Angle Position Encoder Sensor

Output Z indicates the zero position of the magnet, and it is user programmable. The pulse width of Z is selectable as 1, 2, 4, 8, 12, 16 LSBs and 180° as shown in Figure-9 and Figure-10. It is guaranteed that one Z pulse is generated for every rotation round.

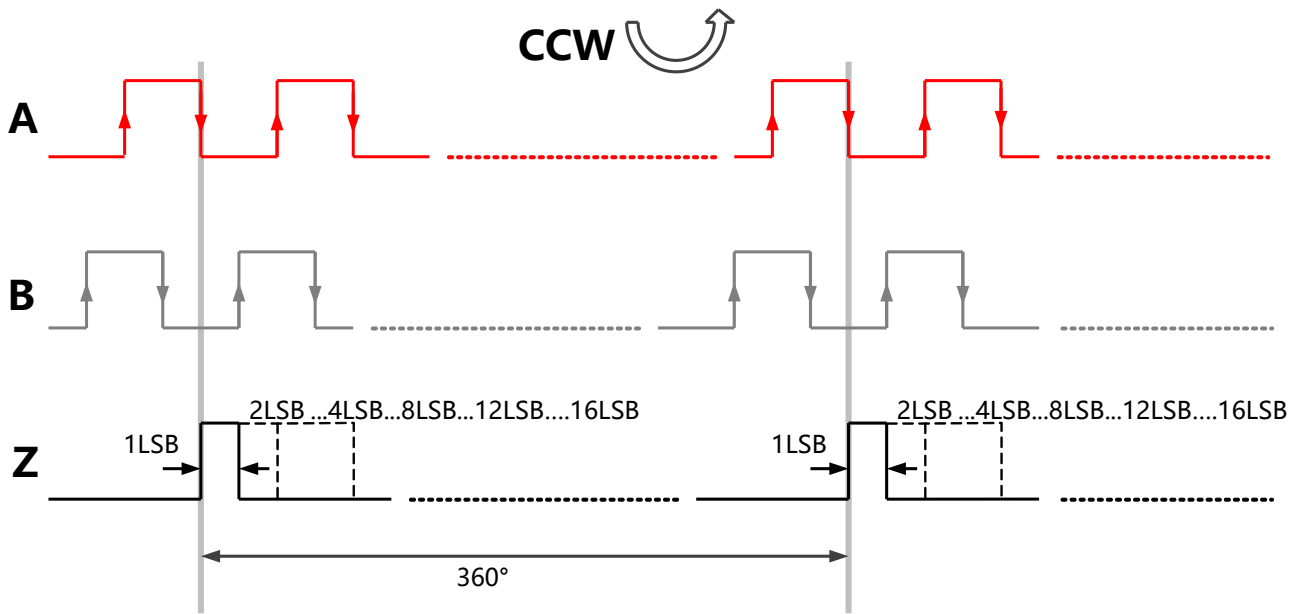

Figure-9: Typical ABZ Output w/i Z Pules Width=1,2,4,8,12 and 16 LSBs

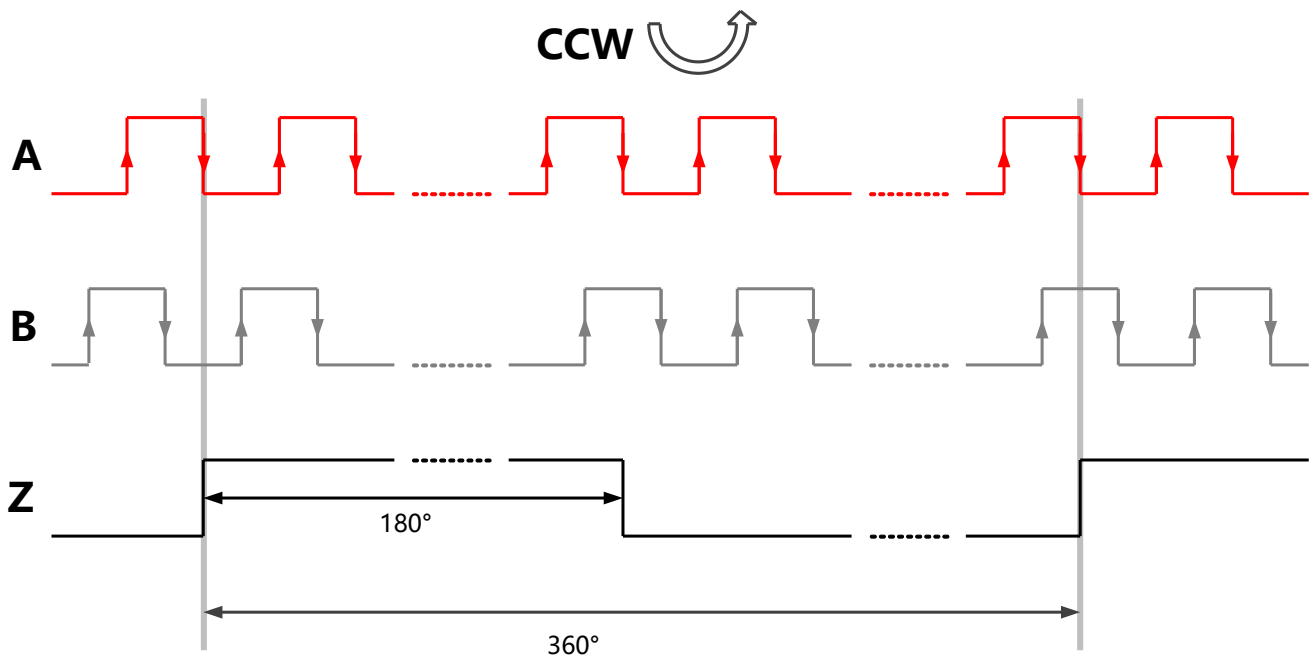

Figure-10: Typical ABZ Output w/i Z pules width=180°

## Hall Based Angle Position Encoder Sensor

ABZ resolution is user programmable as 1~1024 PPR any resolution. The relationship between binary bits, LSBs and PPR resolution of ABZ output are shown in Figure 11 and Figure 12.

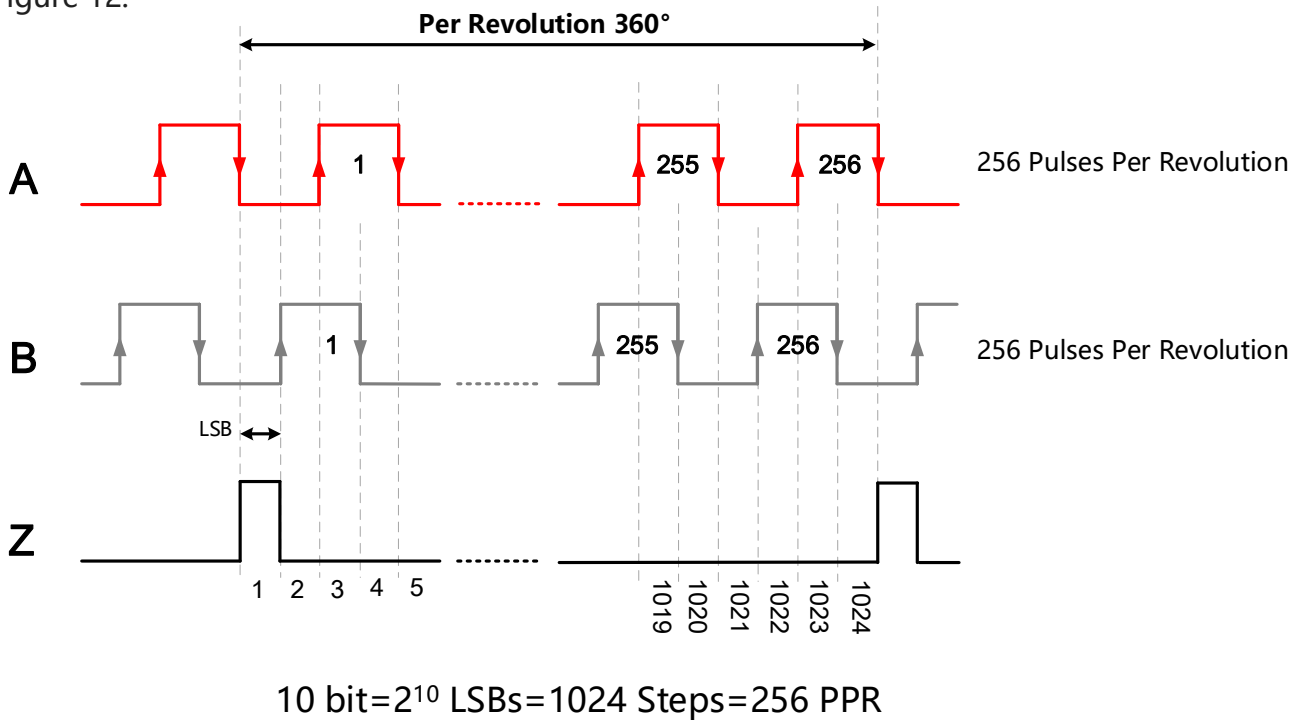

Figure-11: ABZ Output Resolution=10 bit

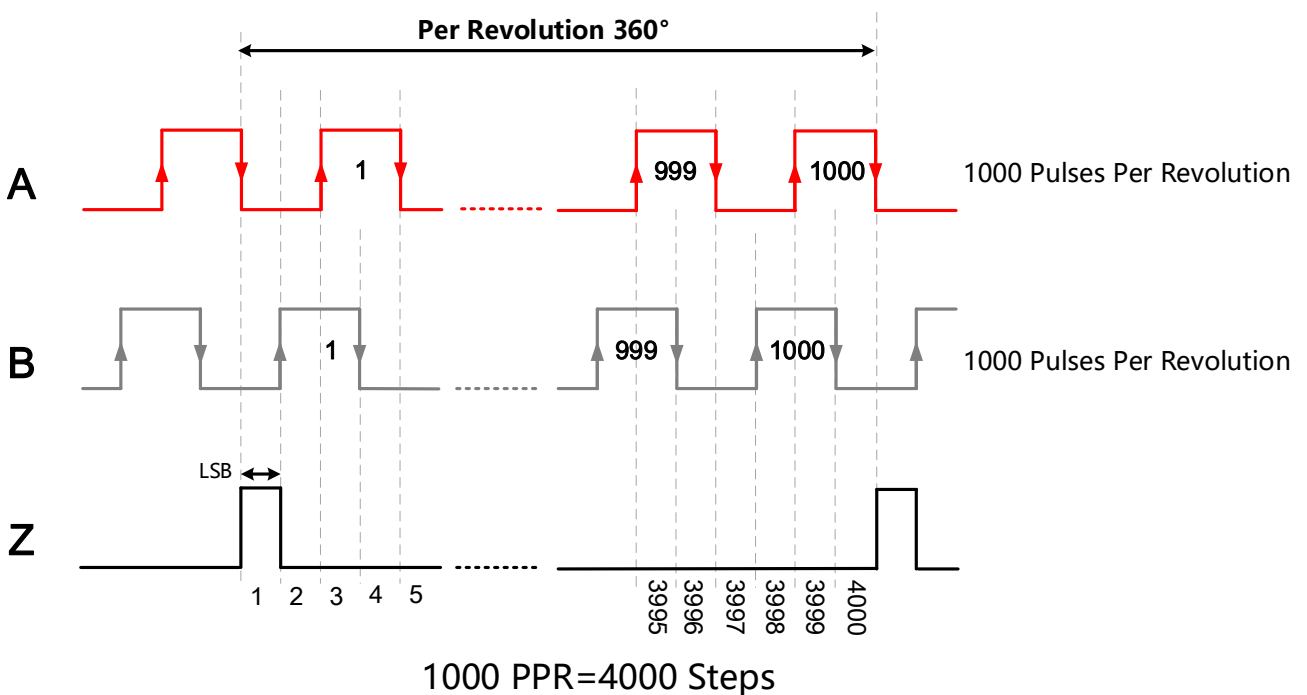

Figure-12: ABZ Output Resolution=1000 PPR

## Hall Based Angle Position Encoder Sensor

The Z/Index pulse width could be programmed

### Z/Index Pulse Width Register (EEPROM)

Reg. Z_Pulse_Width[2:0]	Width (LSBs)	Reg. Z_Pulse_Width[2:0]	Width (LSBs)
000	1	100	12
001	2	101	16
010	4	110	180°
011	8	111	1

The mechanical zero position could be programmed, it is a 12 bits data for 0~360°.

### Zero Position Register (EEPROM)

Register	bit7	bit6	bit5	bit4	bit3	bit2	bit1	bit0
Zero_MSB	NA	Z_PULSE_WIDTH[2:0]			ZERO[11:8]			
Zero_LSB	ZERO[7:0]							

The resolution of ABZ could be programmed by a 10-bit register 'ABZ\_RES'

### ABZ Resolution Register (EEPROM)

Register	bit7	bit6	bit5	bit4	bit3	bit2	bit1	bit0
ABZ_RES	UVW_RES[3:0]				NA	NA	ABZ_RES[9:8]	
ABZ_RES	ABZ_RES[7:0]							

*\* To program EEPROM, please refer Chapter-8*



## Hall Based Angle Position Encoder Sensor

### 7.4 UVW Output Mode

The MT6701 provides U, V and W pulses which are 120° (electrical) out of phase as shown in Figure-13. The cycles of UVW per rotation can be programmed.

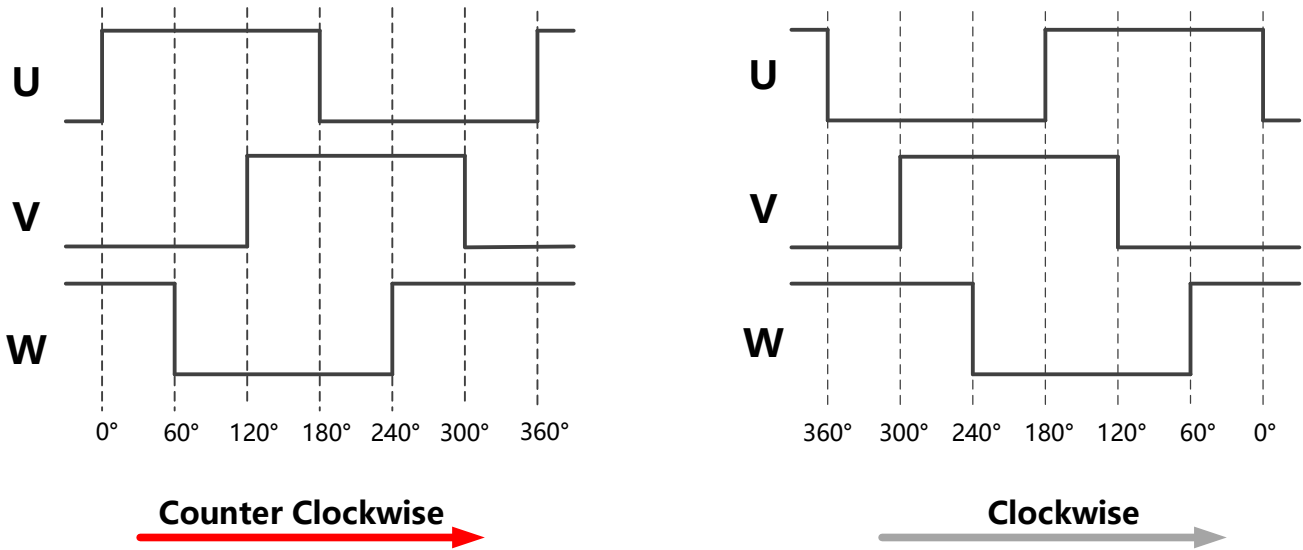

Figure-13: Typical Output Waveform for UVW Mode

#### UVW Pole Pairs Register (EEPROM)

Reg. UVW_RES[3:0]	UVW Pole Pairs
0000	1
0001	2
0010	3
0011	4
0100	5
0101	6
0110	7
0111	8
1000	9
1001	10
1010	11
1011	12
1100	13
1101	14
1110	15
1111	16

## Hall Based Angle Position Encoder Sensor

### 7.5 Analog Output Mode

The MT6701 provides a rail-to-rail linear analog output by a build-in 12-bit DAC as shown in Figure-14. It's a linear transfer function of absolute angle and output voltage. To enable analog output, register 'Output Mode' should be programmed to logic 'Low' .

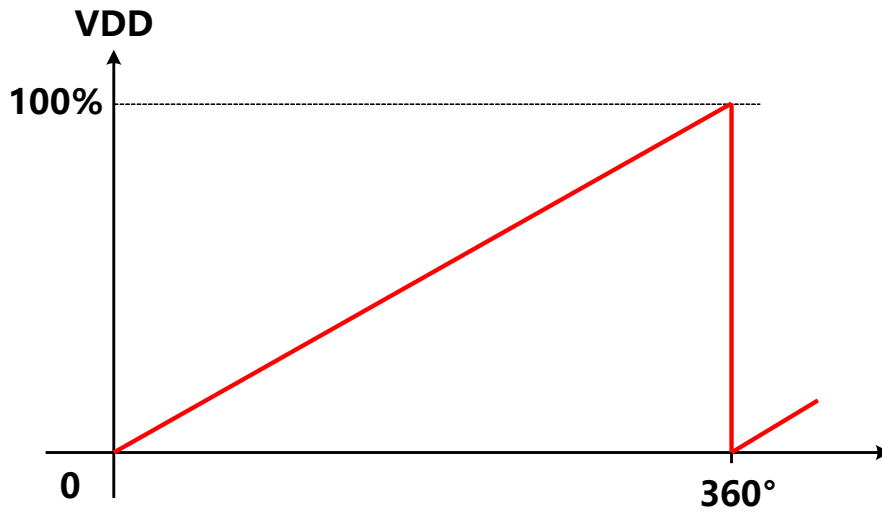

Figure-14: Default Analog Output

#### Analog or PWM Output Control Register (EEPROM)

Reg. Output Mode	Pin.3 (SOP-8), Pin.15 (QFN-16)
0	Analog
1	PWM

The angle and voltage value of start-point, Clamp\_Low (0% or 10%) and Clamp\_High (100% or 90%) could be user programmed, also the Zero Point could be user programmed as shown in Figure 15.

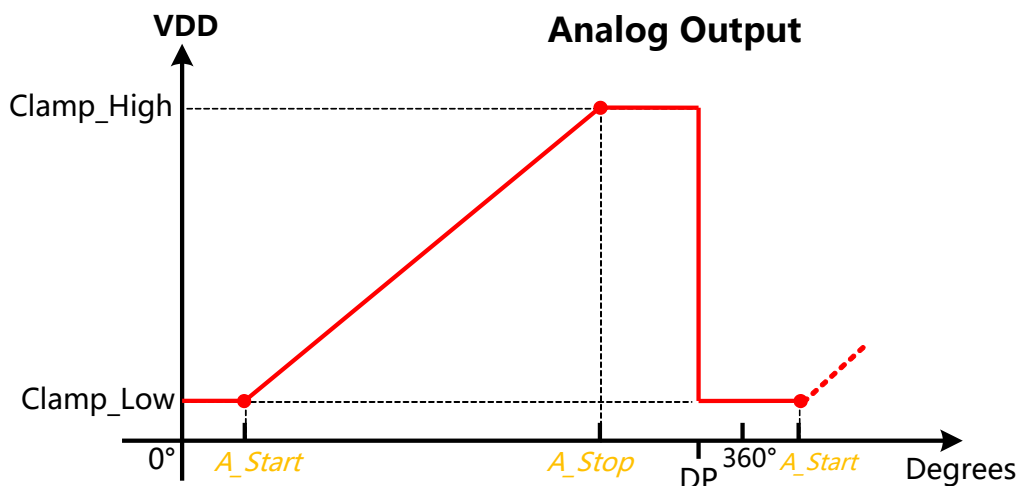

Figure-15: Analog Output Transfer Function

## Hall Based Angle Position Encoder Sensor

### 7.6 Pulse Width Modulation (PWM) Output Mode

The MT6701 provides a digital Pulse Width Modulation (PWM) output, whose duty cycle is proportional to the measured angle as shown in Figure-16.

The PWM output consists of a frame of 4119 PWM clock periods. The angle data is represented with 12-bit resolution in the frame. One PWM clock period represents 0.088° and has a typical duration of 244ns which also could be programmed to be 488ns.

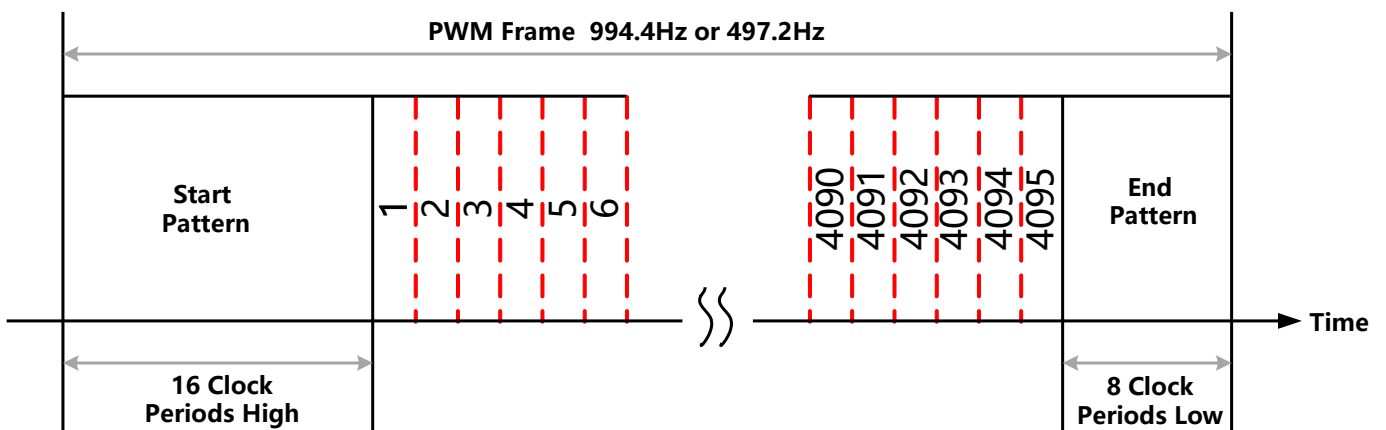

Figure-16: PWM Output Frame

#### PWM Frequency (EEPROM)

Reg. PWM_FREQ	PWM Frame Frequency
0	994.4 Hz
1	497.2 Hz

## Hall Based Angle Position Encoder Sensor

### 7.7 I<sup>2</sup>C Interface

The MT6701 provides a slave I<sup>2</sup>C interface for host MCU to read back digital absolute angle information from its internal registers. The reference circuit for I<sup>2</sup>C interface is shown in Figure-17 and Figure-18, whether the need for pull-up resistor on SCL is determined by MCU, for MT6701 SCL is a digital input.

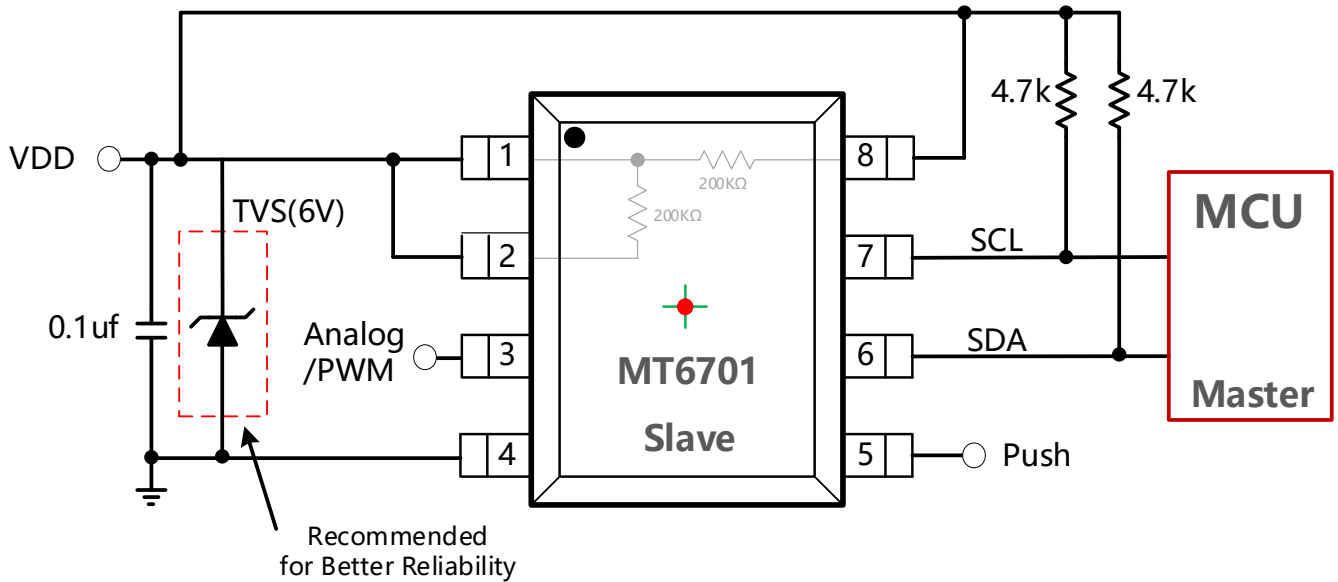

Figure-17: I<sup>2</sup>C Reference Circuit of SOP-8 Package

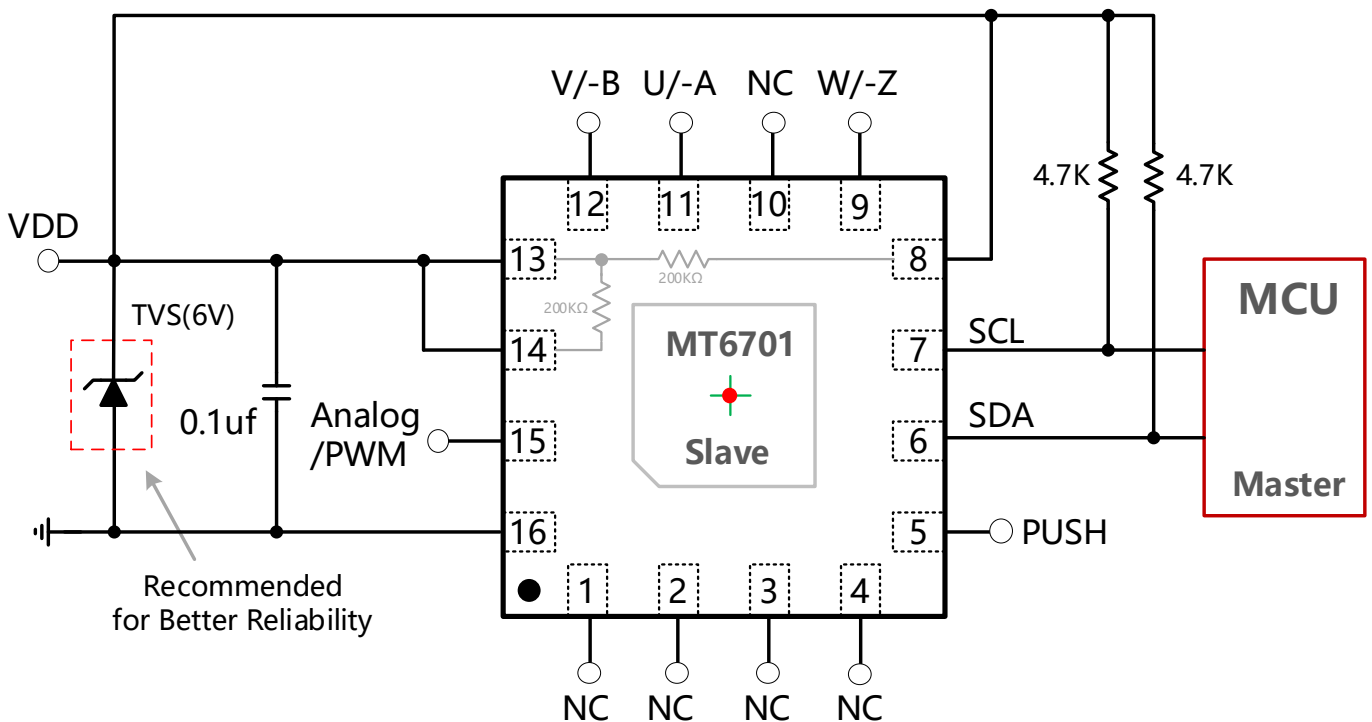

Figure-18: I<sup>2</sup>C Reference Circuit of QFN3x3 Package

## Hall Based Angle Position Encoder Sensor

### 7.7.1 I<sup>2</sup>C Timing Diagram

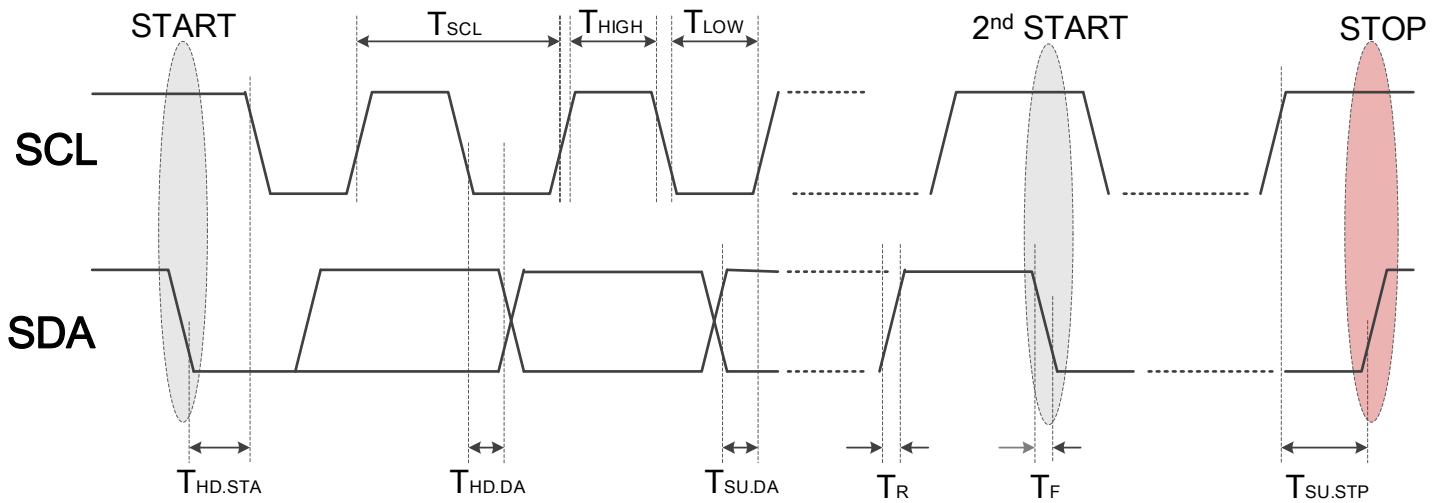

Figure-19: I<sup>2</sup>C Timing Diagram

### I<sup>2</sup>C Timing Parameter

Parameter	Notes	Min.	Max.	Unit
$T_{SCL}$	SCL Clock Period	1	-	$\mu$ s
$T_{HD.STA}$	Hold Time of 'START'	250	-	ns
$T_{LOW}$	Low Phase of SCL	250	-	ns
$T_{HIGH}$	High Phase of SCL	250	-	ns
$T_{SU.DA}$	Setup Time of SDA	100	-	ns
$T_{HD.DA}$	Hold Time of SDA	50	-	ns
$T_R$	Rising Time of SDA/SCL	-	150	ns
$T_F$	Falling Time of SDA/SCL	-	150	ns
$T_{SU.STP}$	Setup Time of 'Stop'	250	-	ns

## Hall Based Angle Position Encoder Sensor

### 7.7.2 I<sup>2</sup>C Read Angle Registers

The default slave ID of MT6701 is b'0000110 in 7-bit binary form (It could be programmed to b'1000110). The 14 bits angle data is stored in internal register 0x03 and 0x04. Please follow the I<sup>2</sup>C timing of Figure-20 to read the angle data from 0x03 and 0x04 registers.

**Note: Please read Register 0x03 first and then read 0x04**

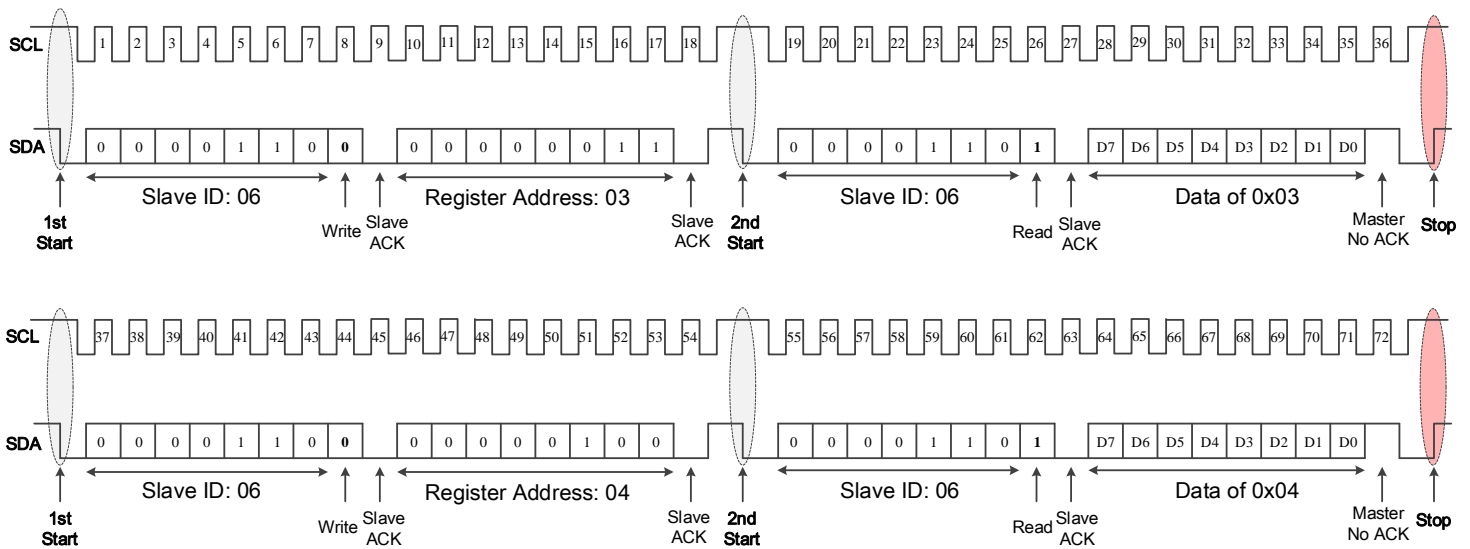

Figure-20: I<sup>2</sup>C Single Byte Read

#### Angle Data Register

Reg. Address	Bit7	Bit6	Bit5	Bit4	Bit3	Bit2	Bit1	Bit0
0x03	Angle[13:6]							
0x04	Angle[5:0]						NA	NA

0~360° absolute angle  $\theta$  could be calculated by the below formula:

$$\theta = \frac{\sum_{i=0}^{13} \text{Angle} \langle i \rangle \cdot 2^i}{16384} \cdot 360^\circ$$

## Hall Based Angle Position Encoder Sensor

### 7.7.3 I<sup>2</sup>C Write Registers

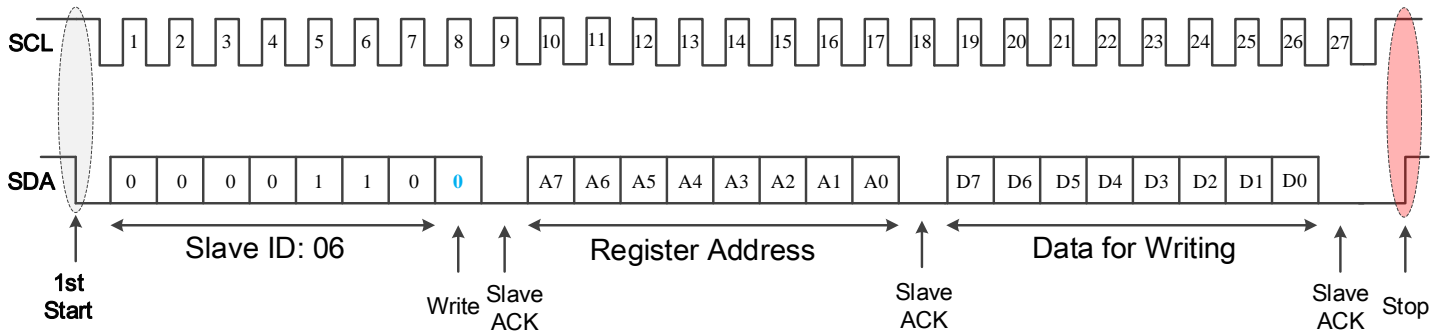

Figure-21: I<sup>2</sup>C Write

## Hall Based Angle Position Encoder Sensor

### 7.8 SSI Interface

The MT6701 also provides an SSI interface for host MCU to read back digital absolute angle information. The reference circuits for SSI interface are shown in Figure-22 and Figure-23.

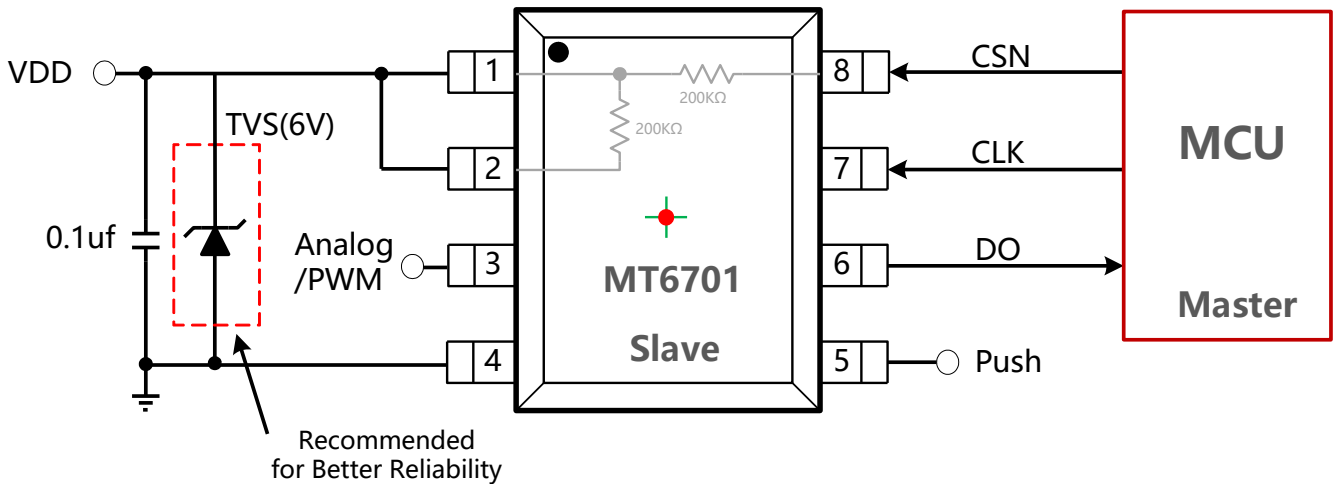

Figure-22: SSI Interface Reference Circuit of SOP-8 Package

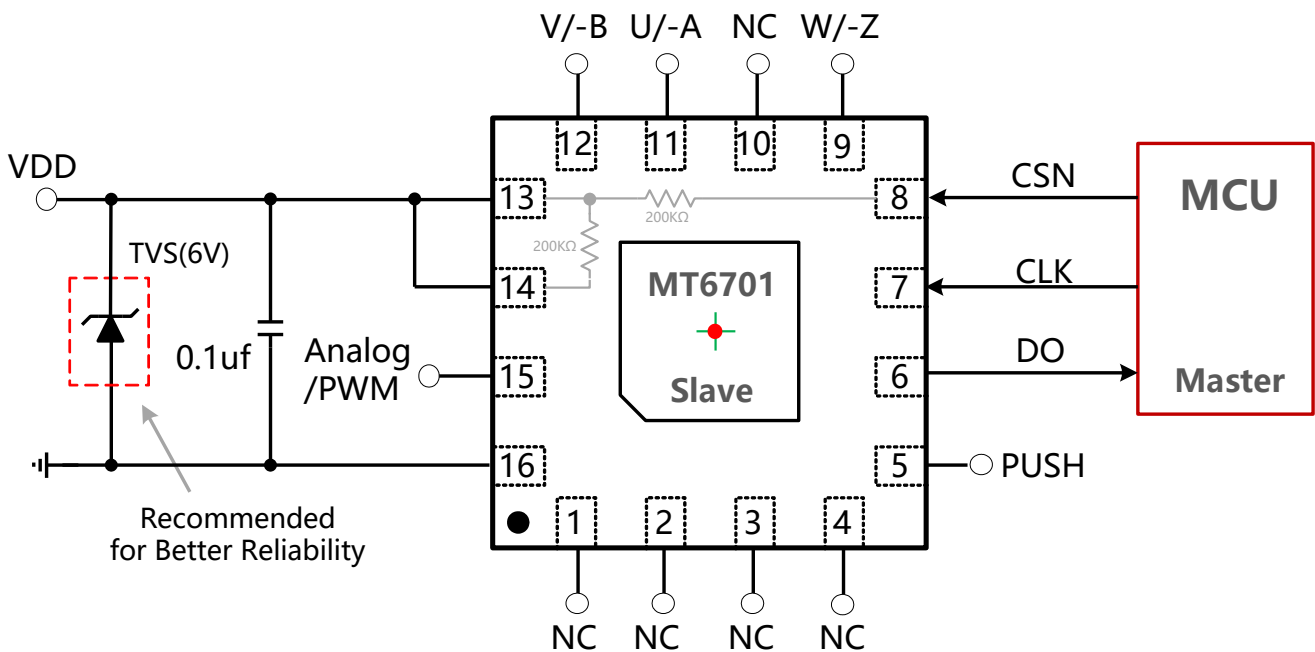

Figure-23: SSI Interface Reference Circuit of QFN-16 Package



## Hall Based Angle Position Encoder Sensor

### 7.8.1 SSI Timing Diagram

The MT6701 SSI is shown in Figure-24, a data transfer starts when CSN is pulled to logic 'Low'. The MT6701 transfers data on the rising edge of CLK, and the data transfer finally stops when CSN is pulled to logic 'High'

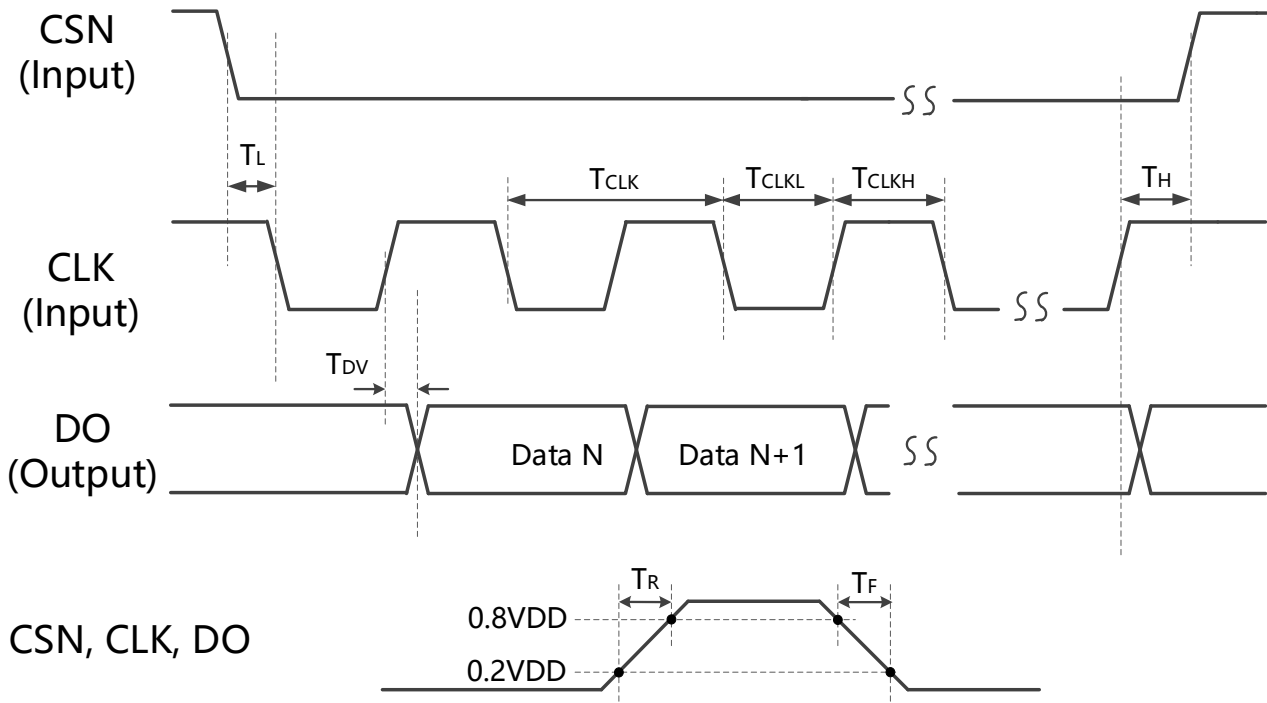

**Figure-24: SSI Timing Diagram**

#### SSI Timing Parameter

Symbol	Notes	Min.	Typ.	Max.	Unit
$T_L$	Time between CSN falling edge and CLK falling edge	100		-	ns
$T_{CLK}$	Clock period	64		-	ns
$T_{CLKL}$	Low period of clock	30		-	ns
$T_{CLKH}$	High period of clock	30		-	ns
$T_H$	Time between CLK last rising edge and CSN rising edge	$0.5 \cdot T_{CLK}$		-	ns
$T_R$	Rise Time of Digital Signal (with 20pf Loading Condition)	-	10	-	ns
$T_F$	Fall Time of Digital Signal (with 20pf Loading Condition)	-	10	-	ns
$T_{DV}$	Data valid time of DO (with 20pf Loading Condition)	-	-	15	ns

## Hall Based Angle Position Encoder Sensor

### 7.8.2 SSI Read Angle

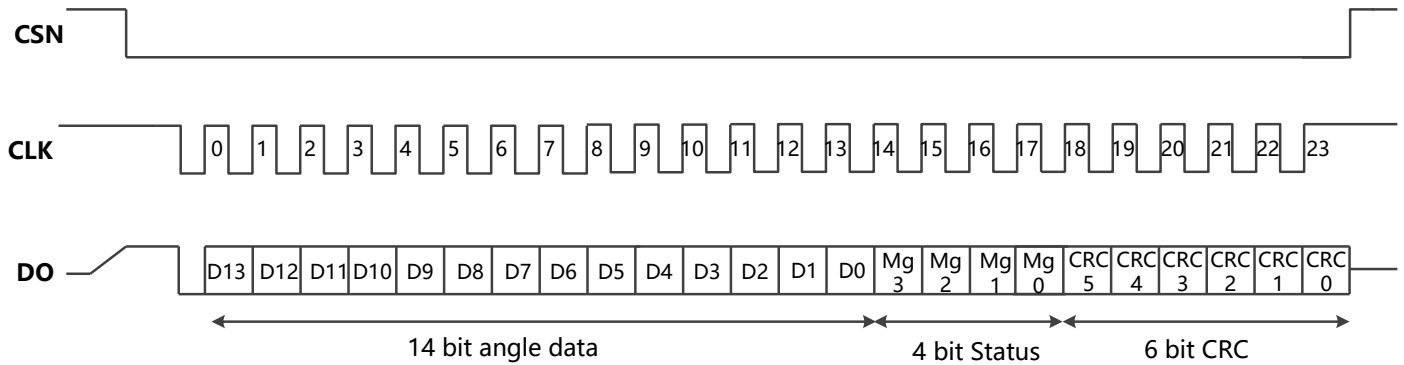

**Figure-25: SSI Data Format**

An SSI data transfer starts when CSN is pulled to logic 'Low', as shown in Figure-25. CLK is the Serial Port Clock, and it is controlled by the SSI master; it is high when there is no SSI transmission. DO (Data Output) is the Serial Port Data Output from MT6701, it is driven at the rising edge of CLK and should be captured at the falling edge of CLK.

**Bit 0-13:** 14-bit Angle Data D[13:0]

**Bit 14-17:** 4-bit Magnetic Field Status Mg[3:0]

**Bit 18-23:** 6-bit CRC Code CRC[5:0]

0~360° absolute angle  $\theta$  could be calculated by the below formula with D[13:0]:

$$\theta = \frac{\sum_{i=0}^{13} D \langle i \rangle \cdot 2^i}{16384} \cdot 360^\circ$$

Mg[3:0] Magnetic Field Status Truth Table:

Mg[1:0]	Status	Mg[2]	Status	Mg[3]	Status
0	Normal	0	Normal	0	Normal
1	Magnetic Field is too Strong	1	Push Button is Detected	1	Loss of Track
2	Magnetic Field is too Weak				
3	-				

CRC Data Range: D[13:0] and Mg[3:0] total 18-bit, D[13] is the MSB, Mg[0] is the LSB

CRC polynomial:  $X^6+X+1$ , MSB steam in first.

## Hall Based Angle Position Encoder Sensor

### 7.9 Pushbutton Output

The MT6701 implements a pushbutton detection function through a dynamic and relative measurement of the orthogonal magnetic field strength. This pushbutton detection function drives the PUSH output pin high when the MT6701 detects a fast (which is less than the time defined by 'PUSH\_DIFF\_DLY' ) increase of the magnetic field (which is larger than the percentage defined by 'PUSH\_THRD' ). After a fast decrease of the magnetic field, the PUSH output is driven low.

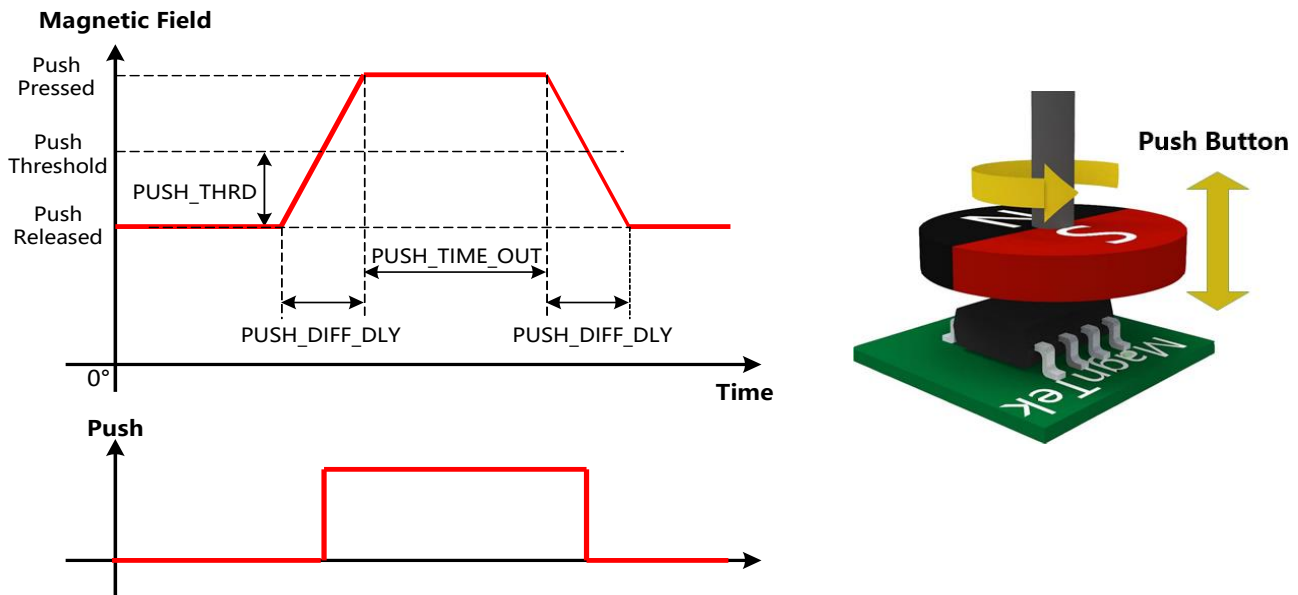

Figure-26: Pushbutton Function

#### **PUSH\_THRD Register (EEPROM)**

Reg. PUSH_THRD	Change Percentage
0	+44%
1	+50%
2	+38%
3	+31%

#### **PUSH\_DIFF\_DLY Register (EEPROM)**

Reg. PUSH_DIFF_DLY	Time (Second)
0	0.5
1	0.25

#### **PUSH\_TIME\_OUT Register (EEPROM)**

Reg. PUSH_TIME_OUT	Time (Second)
0	8
1	16
2	4
3	2

### 8. Register Map & EEPROM Programming

#### 8.1 EEPROM Register Map

Reg. Addr.	bit7	bit6	bit5	bit4	bit3	bit2	bit1	bit0
0x25	UVW_MUX							
0x29		ABZ_MUX					DIR	
0x30	UVW_RES[3:0]						ABZ_RES[9:8]	
0x31	ABZ_RES[7:0]							
0x32	HYST[2]	Z_PULSE_WIDTH[2:0]			ZERO [11:8]			
0x33	ZERO [7:0]							
0x34	HYST[1:0]							
0x38	PWM_FREQ	PWM_POL	OUT_MODE					
0x3E	A_STOP[11:8]				A_START[11:8]			
0x3F	A_START[7:0]							
0x40	A_STOP[7:0]							

**Warning: the register bits which filled by ■ are reserved by MagnTek, please DO NOT change the value of these bits!!!**

#### \*UVW\_MUX (Address 0x25[7])

UVW\_MUX register contains the configuration data of UVW output type.

UVW_MUX	UVW Output Type(Only for QFN Package)
0x0	UVW
0x1	-A-B-Z

#### \*ABZ\_MUX (Address 0x29[6])

ABZ\_MUX register contains data of ABZ output type.

ABZ_MUX	ABZ Output Type
0x0	ABZ
0x1	UVW

#### \*DIR(Address 0x29[1])

DIR register contains the configuration data of output rotation direction

DIR	Output Direction
0x0	CCW
0x1	CW

## Hall Based Angle Position Encoder Sensor

### \*UVW\_RES[3:0] (Address 0x30[7:4])

UVW\_RES register contains the configuration data of UVW output resolution (Pole-Pairs).

Reg. UVW_RES<3:0>	UVW Output Pole Pairs
0x0	1
0x1	2
0x2	3
.....	.....
0xD	14
0xE	15
0xF	16

### \*ABZ\_RES[9:0] (Address 0x30[1:0] & 0x31[7:0])

ABZ\_RES register contains the configuration data of ABZ output resolution (PPR).

Reg. ABZ_RES<9:0>	ABZ Resolution (Pulse per Round)
0x000	1
0x001	2
0x002	3
.....	.....
0x3FD	1022
0x3FE	1023
0x3FF	1024

### \*HYST[2:0] (Address 0x32[7] & 0x34[7:6])

HYST register contains the configuration data of hysteresis filter parameter.

HYST	Hysteresis (LSB)
0x0	1
0x1	2
0x2	4
0x3	8
0x4	0
0x5	0.25
0x6	0.5
0x7	1

## Hall Based Angle Position Encoder Sensor

### \*Z\_PULSE\_WIDTH[2:0] (Address 0x32[6:4])

Z\_PULSE\_WIDTH register contains the configuration data of Z pulse width (Fig.9 & Fig.10)

HYST	Z Pulse Width
0x0	1 LSB
0x1	2 LSB
0x2	4 LSB
0x3	8 LSB
0x4	12 LSB
0x5	16 LSB
0x6	180°
0x7	1 LSB

### \*ZERO[11:0] (Address 0x32[3:0] & 0x33[7:0])

ZERO register contains the configuration data of zero-degree position.

ZERO	Zero Degree Position
0x000	0°
0x001	0.088°
0x002	0.176°
...	...
0xFFD	359.736°
0xFFE	359.824°
0xFFF	359.912°

### \*PWM\_FREQ (Address 0x38[7])

PWM\_FREQ register contains the configuration data of PWM frame frequency

PWM_FREQ	PWM Frame Frequency
0x0	994.4 Hz
0x1	497.2 Hz

### \*PWM\_POL (Address 0x38[6])

PWM\_POL register contains data of PWM polarity.

PWM_POL	PWM Polarity
0x0	High Level Valid
0x1	Low Level Valid

## Hall Based Angle Position Encoder Sensor

### \*OUT\_MODE(Address 0x38[5])

OUT\_MODE register contains the configuration data of 'Out' Pin Mode

OUT_MODE	'Out' Pin Mode
0x0	Analog Output
0x1	PWM Output

### \*A\_START[11:0] (Address 0x3E[3:0] & 0x3F[7:0])

A\_START register contains the configuration data of start-point of analog output (Fig.15)

A_START	Analog/PWM Start Angle
0x000	0°
0x001	0.088°
0x002	0.176°
...	...
0xFFD	359.736°
0xFFE	359.824°
0xFFF	359.912°

### \*A\_STOP[11:0] (Address 0x3E[7:4] & 0x40[7:0])

A\_STOP register contains the configuration data of stop-point of analog output (Fig.15)

A_STOP	Analog/PWM Stop Angle
0x000	0°
0x001	0.088°
0x002	0.176°
...	...
0xFFD	359.736°
0xFFE	359.824°
0xFFF	359.912°

## Hall Based Angle Position Encoder Sensor

### 8.2 EEPROM Programming

Reg. Addr.	bit7	bit6	bit5	bit4	bit3	bit2	bit1	bit0
0x25	UVW_MUX							
0x29		ABZ_MUX					DIR	
0x30	UVW_RES[3:0]						ABZ_RES[9:8]	
0x31	ABZ_RES[7:0]							
0x32	HYST[2]	Z_PULSE_WIDTH[2:0]			ZERO [11:8]			
0x33	ZERO [7:0]							
0x34	HYST[1:0]							
0x38	PWM_FREQ	PWM_POL	OUT_MODE					
0x3E	A_STOP[11:8]				A_START[11:8]			
0x3F	A_START[7:0]							
0x40	A_STOP[7:0]							

**Warning: the register bits which filled by █ are reserved by MagnTek, please DO NOT change the value of these bits!!!**

Customer can program the EEPROM registers by I<sup>2</sup>C interface (Fig.17 & Fig.18) and follow the below steps. **When programming EEPROM, must keep 4.5V < VDD < 5.5V.**

Step	Operation
<b>Writing Register</b>	Writing the right value to the target EEPROM registers (Do Not Change the <span style="background-color: #800000; color: #800000;">█</span> bits, customer should read out the <span style="background-color: #800000; color: #800000;">█</span> bits and logic these bits 'or' with others)
<b>Programming Key</b>	Write value '0xB3' to Register '0x09'
<b>Programming Command</b>	Write value '0x05' to Register '0x0A'
<b>Programming (VDD &gt; 4.5V)</b>	Waiting >600ms without any operation to MT6701
<b>Check Programming Data</b>	Power-down MT6701 and then power-up it again, read the EEPROM register to check if the data is successfully programmed



### 9. Mechanical Angle Direction

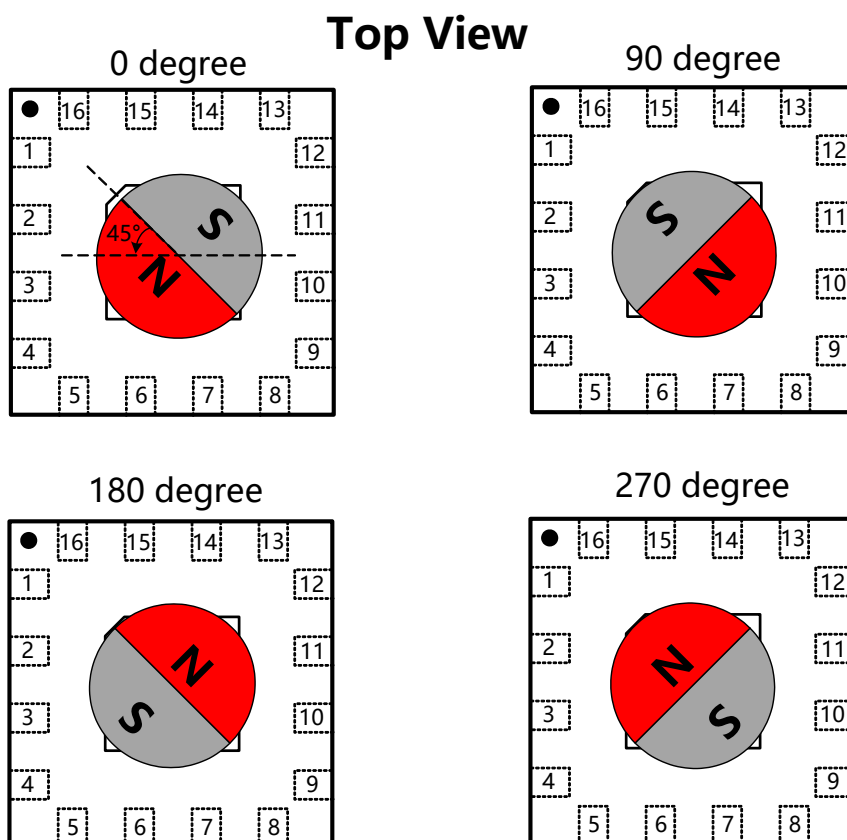
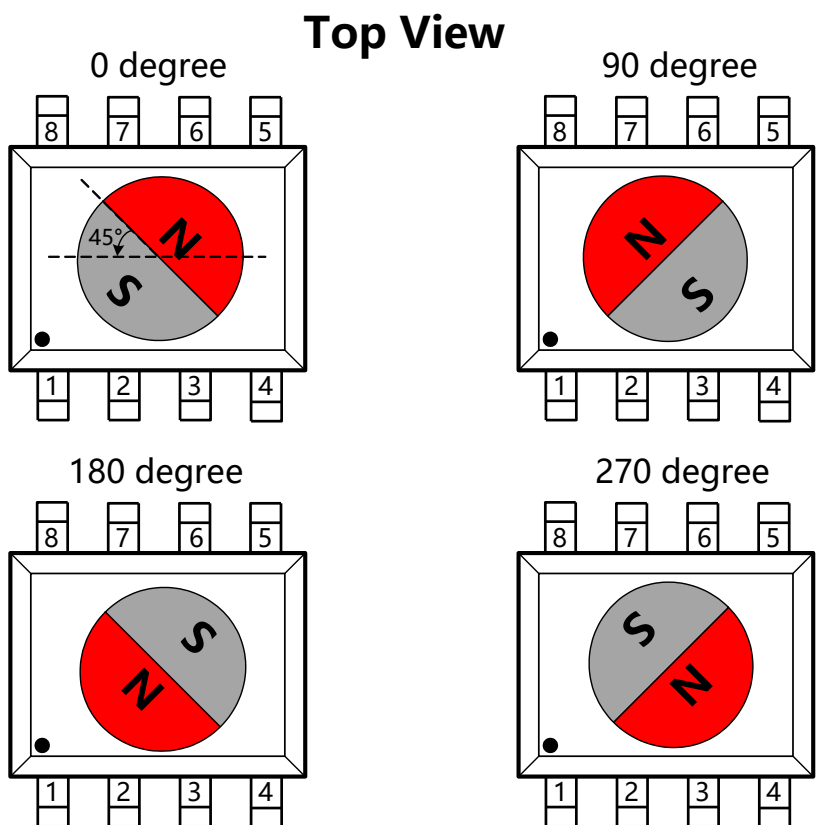

**Figure-27: Mechanical Angle Position**

### 10. Package Information

#### 10.1 SOP-8 Package

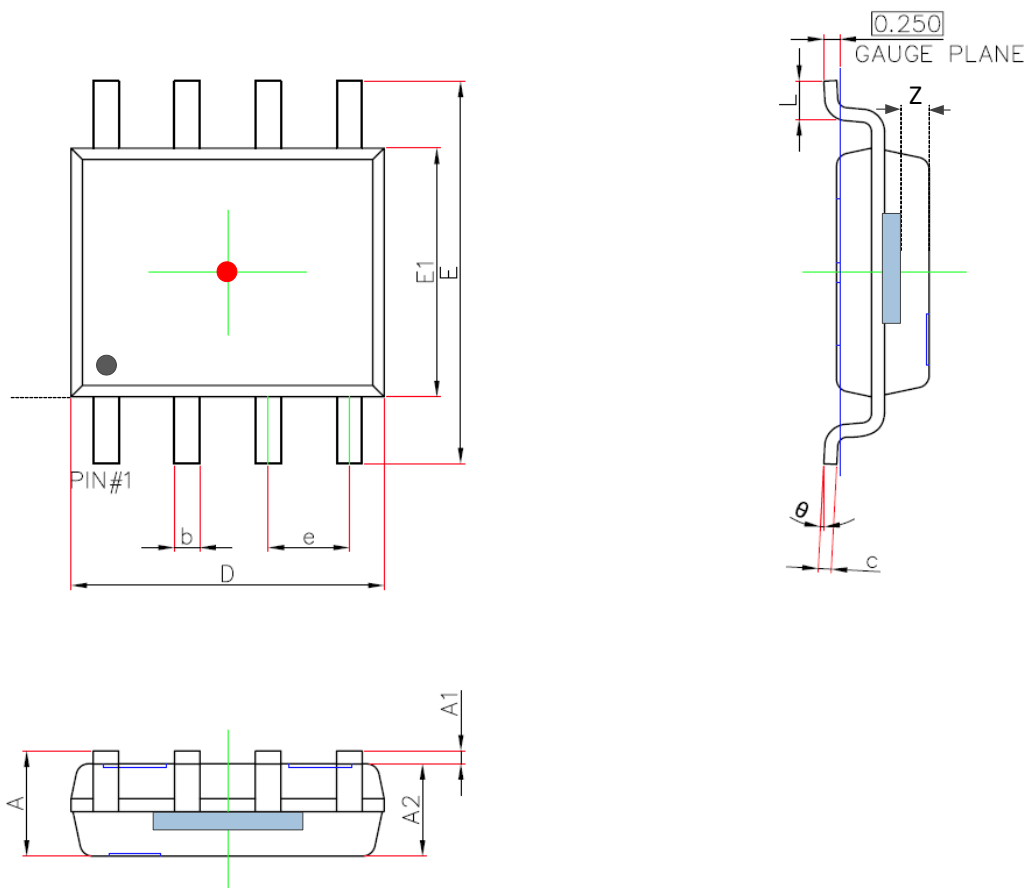

Symbol	Dimensions in Millimeters		Dimensions in Inches	
	Min.	Max.	Min.	Max
A	1.450	1.750	0.057	0.069
A1	0.100	0.250	0.004	0.010
A2	1.350	1.550	0.053	0.061
b	0.330	0.510	0.013	0.020
c	0.170	0.250	0.007	0.010
D	4.700	5.100	0.185	0.201
E	5.800	6.200	0.228	0.244
E1	3.800	4.000	0.150	0.157
e	1.270(BSC)		0.050(BSC)	
L	0.400	1.270	0.016	0.050
θ	0°	8°	0°	8°
Z	0.45	0.65	0.018	0.026

## Hall Based Angle Position Encoder Sensor

### 10.2 QFN-16 Package

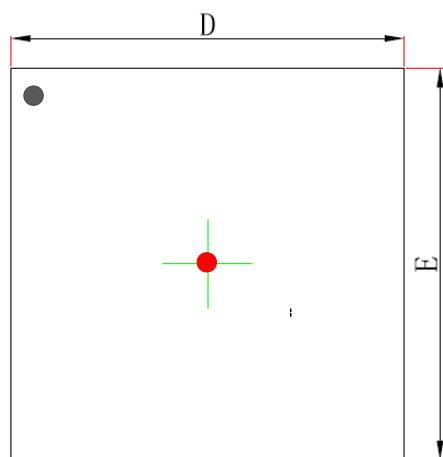

**Top View**

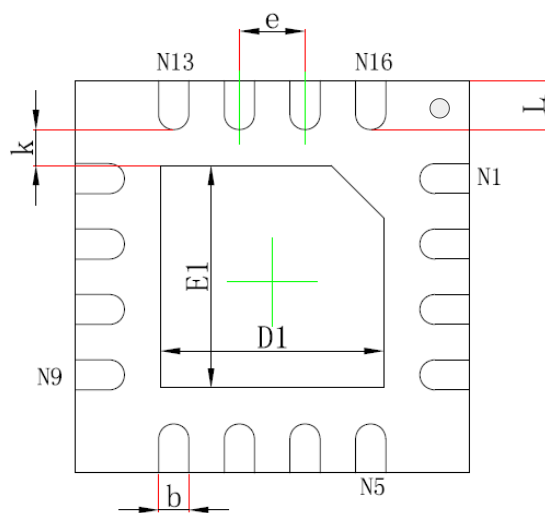

**Bottom View**

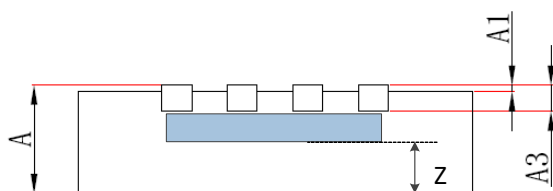

Symbol	Dimensions in Millimeters		Dimensions in Inches	
	Min.	Max.	Min.	Max.
A	0.700	0.800	0.028	0.031
A1	0.000	0.050	0.000	0.002
A3	0.203REF		0.008REF	
D	2.900	3.100	0.114	0.122
E	2.900	3.100	0.114	0.122
D1	1.600	1.800	0.063	0.071
E1	1.600	1.800	0.063	0.071
k	0.275REF		0.011REF	
b	0.180	0.300	0.007	0.012
e	0.500REF		0.020REF	
L	0.300	0.500	0.012	0.020
Z	0.220	0.420	0.009	0.017

### 11. Copy Rights and Disclaimer

1. This document may not be reproduced or duplicated, in any form, in whole or in part without prior written consent of MagnTek . Copyrights © 2020, MagnTek Incorporated.
2. MagnTek reserves the right to make changes to the information published in this document at anytime without notice.
3. MagnTek' s products are limited for use in normal commercial applications. MagnTek' s products are not to be used in any device or system, including but not limited to medical life support equipment and system.

For the latest version of this document, please visit our website: [www.magntek.com.cn](http://www.magntek.com.cn)

### 12. Revision History

Revision Number	Date	Comments
1.0	2020.03	Initial Release
1.1	2020.06	Update EEPROM Programming Condition : 4.5V<VDD<5.5V
1.2	2020.07	Update POD
1.3	2020.09	Update Mechanical Angle
1.4	2021.01	Update PWM Description
1.5	2021.03	Update PWM Clock Duration
1.6	2022.05	Add Part Number List Add Power-on AB Pulses Indicating Absolute Position